

This guide provides functionality rules to power on/off the SF-2110 receiver when the ignition wire on Port C is used.

Functionality Rules: Interaction of Front Panel On/Off Switch & Ignition Pin

- ✓ If the unit is powered off from the front panel On/Off switch:
  - Applying +7VDC or greater to the Ignition pin turns the unit on
  - Removing power from the Ignition pin turns the unit off
- ✓ If the unit is turned on from the front panel On/Off switch, the Ignition pin is over-ridden and will not function.
- ✓ If the unit is turned off from the Ignition pin, the front panel On/Off switch is over-ridden and will not function.
- ✓ If the unit is turned on from the Ignition pin and the user wishes to use the On/Off switch for future on/off procedures, the unit must be turned off from the front panel On/Off switch.



On/Off

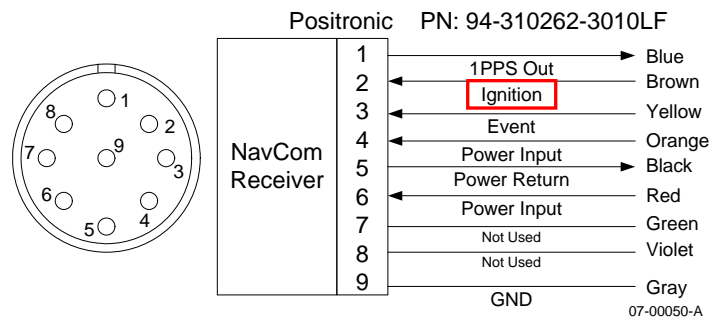

Ignition Pin

