

# SF-2050

## GPS Products User Guide



### NavCom Technology, Inc.

20780 Madrona Avenue  
Torrance, California 90503 USA

Tel: +1 310.381.2000

Fax: +1 310.381.2001

[sales@navcomtech.com](mailto:sales@navcomtech.com)

[www.navcomtech.com](http://www.navcomtech.com)

P/N: 96-310002-3001



A John Deere Company

This page is left blank intentionally

---

## Notices

SF-2050 GPS Products User Guide  
P/N 96-310002-3001  
Revision F  
April 2007

Serial Number: \_\_\_\_\_

Date Delivered: \_\_\_\_\_

Purchased From: \_\_\_\_\_

## Copyright

© 2007 by NavCom Technology, Inc.

All rights reserved. No part of this work or the computer program(s) described herein may be reproduced, stored, or transmitted by any means, without the expressed written consent of the copyright holders. Translation in any language is prohibited without the expressed written consent of the copyright holders.

## Trademarks

'find your way', 'NavCom Globe' and 'NAVCOM TECHNOLOGY' logos are trademarks of NavCom Technology, Inc. StarFire™ is a registered trademark of Deere & Company. All other product and brand names are trademarks or registered trademarks of their respective holders.

## FCC Notice

This device complies with Part 15 of the FCC Rules. Operation is subject to the following two conditions:

1. This device may not cause harmful interference, and
2. This device must accept any interference received, including interference that may cause undesired operation.

The GPS sensor has been tested in accordance with FCC regulations for electromagnetic interference. This does not guarantee non-interference with other equipment. Additionally, the GPS sensor may be adversely affected by nearby sources of electromagnetic radiation.

The Global Positioning System is under the control of the United States Air Force. Operation of the GPS satellites may be changed at any time and without warning.

## User Notice

NavCom Technology, Inc. shall not be responsible for any inaccuracies, errors, or omissions in information contained herein, including, but not limited to, information obtained from third party sources, such as publications of other companies, the press, or competitive data organizations.

This publication is made available on an “as is” basis and NavCom Technology, Inc. specifically disclaims all associated warranties, whether express or implied. In no event will NavCom Technology, Inc. be liable for direct, indirect, special, incidental, or consequential damages in connection with the use of or reliance on the material contained in this publication, even if advised of the possibility of such damages. NavCom Technology, Inc. reserves the right to make

---

improvements or changes to this publication and the products and services herein described at any time, without notice or obligation.

### Limited Warranty

NavCom Technology, Inc., warrants that its products will be free from defects in workmanship at the time of delivery. Under this limited warranty, parts found to be defective or defects in workmanship will be repaired or replaced at the discretion of NavCom Technology, Inc., at no cost to the Buyer, provided that the Buyer returns the defective product to NavCom Technology, Inc. in the original supplied packaging and pays all transportation charges, duties, and taxes associated with the return of the product. Parts replaced during the warranty period do not extend the period of the basic limited warranty.

This provision does not extend to any NavCom Technology, Inc. products, which have been subjected to misuse, accident or improper installation, maintenance or application, nor does it extend to products repaired or altered outside the NavCom Technology, Inc. production facility unless authorized in writing by NavCom Technology, Inc.

*This provision is expressly accepted by the buyer in lieu of any or all other agreements, statements or representations, expressed or implied, in fact or in law, including the implied warranties of merchantability and fitness for a particular purpose and of all duties or liabilities of NavCom Technology, Inc. To the buyer arising out of the use of the goods, and no agreement or understanding varying or extending the same will be binding upon NavCom Technology, Inc. unless in writing, signed by a duly-authorized officer of NavCom Technology, Inc.*

This limited warranty period is one (1) year from date of purchase.

---

## StarFire™ Licensing

The StarFire™ signal requires a subscription that must be purchased in order to access the service. Licenses are non-transferable, and are subject to the terms of the StarFire™ Signal License agreement. For further details on the StarFire™ Signal Network, its capabilities, terms and conditions visit [www.navcomtech.com](http://www.navcomtech.com) or send an email inquiry to [sales@navcomtech.com](mailto:sales@navcomtech.com)

## USG FAR

### Technical Data Declaration (Jan 1997)

The Contractor, NavCom Technology, Inc., hereby declares that, to the best of its knowledge and belief, the technical data delivered herewith under Government contract (and subcontracts, if appropriate) are complete, accurate, and comply with the requirements of the contract concerning such technical data

## Global Positioning System

Selective availability (S/A code) was disabled on 02 May 2000 at 04:05 UTC. The United States government has stated that present GPS users use the available signals at their own risk. The US Government may at any time end or change operation of these satellites without warning.

The U.S. Department of Commerce Limits Requirements state that all exportable GPS products contain performance limitations so that they cannot be used to threaten the security of the United States.

Access to satellite measurements and navigation results will be limited from display and recordable output when predetermined values of velocity and altitude are exceeded. These threshold values are far

in excess of the normal and expected operational parameters of the SF-2050 GPS Sensor.

## Revision History

Rev A (Dec 2002)	Initial release
Rev B (Feb 2003)	Inserted missing block bracket (open) in Table 2 Cell A2
Rev C (Nov 2003)	Replaced Redondo Beach contact information with Torrance.
Rev D (Mar 2005)	<p>Added appendix detailing specifications for Event input; wiring diagram, Event HI/LO wiring table, and message output instructions.</p> <p>Minor grammatical corrections.</p> <p>Used production model photo of SF-2050 on cover.</p>
Rev E (Aug 2005)	<p>Added USG FAR Statement</p> <p>Made changes that denote NCT-2100 where applicable</p> <p>Minor formatting changes to wording, tables, etc.</p> <p>Changed Controller &amp; Data Logger graphic to better depict the text.</p> <p>Changed antenna output voltage to 4.6 nominal</p> <p>Changed power table to reflect NCT-2100 levels</p>

(continued on next page)

---

Rev F (Apr 2007)	Format change Add content for SF-2050R Updated Specifications Add RF cabling requirements Add antenna patterns Add related standards Add related documents Expand product overview Add NMEA Add DC to DC cable Add RTK Link LED Add antenna placement guidelines Update dimensional drawings Add block diagrams Remove datum description from text body Add figures for port settings Expand port configuration descriptions Add DCE DTE definitions Add wiring diagrams
------------------	--

This page is left blank intentionally

## Table of Contents

<b>Notices</b>	<b>ii</b>
Copyright	i
Trademarks	i
FCC Notice	ii
User Notice	ii
Limited Warranty	iii
StarFire™ Licensing	iv
USG FAR	iv
Global Positioning System	iv
<b>Revision History</b>	<b>vi</b>
<b>Table of Contents</b>	<b>ix</b>
<b>List of Figures</b>	<b>xii</b>
<b>List of Tables</b>	<b>xiii</b>
<b>Use of this Document</b>	<b>xiv</b>
Related Documents	xiv
StarUtil User Guide	xiv
Technical Reference Manual	xv
RINEXUtil User Guide	xv
Integrators Toolkit	xv
Related Standards	xv
ICD-GPS-200	xv
RTCM-SC-104	xv
CMR, CMR+	xvi
NMEA-0183	xvi
<b>Chapter 1 Introduction</b>	<b>17</b>
System Overview	17
GPS Sensor System	17
Accuracy	18
Features ... Applies to All Models	18
Output Data Rate	18
NCT Binary Proprietary Data	19
NMEA-0183 Data	19
Models	20
SF-2050G	20
SF-2050M	21
SF-2050R	21
Antennae	22
Standard	22
Airborne (option)	22

---

L-band (option – SF-2050R only) .....	23
Controller .....	23
Applications .....	25
Unique Features .....	25
<b>Chapter 2 Interfacing.....</b>	<b>29</b>
Electrical Power.....	29
Communication Ports .....	32
CAN Bus/Event .....	35
Event .....	35
1 PPS .....	36
Indicator Panel.....	37
<b>Chapter 3 Installation .....</b>	<b>41</b>
Standard Antenna .....	41
L-Band Antenna (SF-2050R Only) .....	43
GPS Sensor.....	44
Block Diagrams .....	46
Communication Port Connectivity .....	48
GPS Antenna Connector.....	49
<b>Chapter 4 Configuration .....</b>	<b>53</b>
Factory Default Settings .....	54
Message Descriptions .....	56
3 <sup>rd</sup> Party Controller Configuration Settings.....	57
<b>Chapter 5 Safety Instructions.....</b>	<b>59</b>
Transport .....	59
Maintenance .....	59
External Power Source.....	59
Safety First .....	60
<b>A GPS Module Specifications .....</b>	<b>61</b>
Features .....	61
Time-To-First-Fix.....	62
Dynamics.....	62
Measurement Performance.....	63
User programmable output rates .....	64
Data Latency .....	64
1PPS .....	64
Connector Assignments .....	64
Input/Output Data Messages.....	65
LED Display Functions (Default) .....	65
Satellite Based Augmentation System Signals .....	66
Physical and Environmental .....	66
<b>B Antenna Specifications .....</b>	<b>67</b>
Radiation Pattern.....	69

---

	Radiation Pattern.....	73
<b>C</b>	<b>StarFire™ 75</b>	
	Description.....	75
	Infrastructure .....	76
	Reliability .....	77
	How to Access the StarFire™ Service .....	78
<b>D</b>	<b>Event Input Configuration .....</b>	<b>81</b>
<b>Glossary</b>	.....	<b>83</b>

---

## List of Figures

Figure 1: SF-2050 Supplied Equipment .....	24
Figure 2: Universal Power Adapter.....	30
Figure 3: AC Power Cord .....	30
Figure 4: Optional DC Power Cable .....	31
Figure 5: SF-2050 Front View .....	33
Figure 6: NavCom Serial Cable.....	34
Figure 7: SF-2050M Only Back View .....	35
Figure 8: SF-2050 Indicator Panel.....	37
Figure 9: Standard GPS/L-band Antenna.....	41
Figure 10: SF-2050 Base Plate Dimensions .....	45
Figure 11: SF-2050G/M Block Diagram .....	46
Figure 12: Radio Port Configuration, StarUtil .....	47
Figure 13: SF-2050R Block Diagram.....	47
Figure 14: Communication Port Connections.....	49
Figure 15: StarUtil NMEA Message List.....	54
Figure 16: StarUtil Rover Navigation Setup.....	55
Figure B1: AN-2004T Antenna Dimensions .....	68
Figure B2: AN-2004T Radiation Pattern.....	69
Figure B3: L-Band Antenna Dimensions .....	71
Figure B4: L-Band Mounts.....	72
Figure B5: AN-2001L Radiation Pattern .....	73
Figure C1: StarFire™ Network .....	80
Figure D1: Event Cable Wiring Diagram .....	81
Figure D2: PPS & Event Latch Configuration.....	82
Figure D3: Event Latch Output Rate Configuration .	82
Figure G1: DTE to DCE RS-232 Pin Assignments..	86

## List of Tables

Table 1: Supplied Equipment.....	24
Table 2: External Power Cable Pin-Out .....	29
Table 3: Optional DC Pwr Cable Pin Assignments ..	31
Table 4: Serial Cable Pin-Outs .....	33
Table 5: Link LED Indication (Default) .....	38
Table 6: Base Station Indication .....	38
Table 7: GPS Light Indication .....	39
Table 8: Acceptable Cable Lengths .....	50
Table 9: Factory Setup Proprietary Msg COM 2 .....	56
Table B1: Standard Antenna.....	67
Table B2: L-band SF-2050R Antenna.....	70
Table D1: Event Wiring Connections .....	81

---

## Use of this Document

This User Guide is intended to be used by someone familiar with the concepts of GPS and satellite surveying equipment.



Note indicates additional information to make better use of the product.



This symbol means Reader Be Careful. Indicates a caution, care, and/or safety situation. The user might do something that could result in equipment damage or loss of data.



This symbol means Danger. You are in a situation that could cause bodily injury. Before you work on any equipment, be aware of the hazards involved with electrical and RF circuitry and be familiar with standard practices for preventing accidents.

Revisions to this User Guide can be obtained in a digital format from

<http://www.navcomtech.com/Support/>

## Related Documents

**StarUtil User Guide**  
P/N 96-310008-3001

Describes the operation and use of NavCom's Windows based control program (included on CD)

## Technical Reference Manual P/N 96-3120001-3001

Describes the control and output data message formats utilized by this instrument (for customer programming purposes; included on CD)

## RINEXUtil User Guide P/N 96-310021-2101

Describes the conversion program used no NavCom proprietary output data message formats to RINEX ver 2.10 observation and navigation files (for customer programming purposes; included on CD)

## Integrators Toolkit P/N 97-310020-3001

Provides additional instruction and tools for developing control programs for this instrument (not included in the packaging material; contact <http://www.navcomtech.com/Support/> for a copy)

## Related Standards

### ICD-GPS-200

NAVSTAR GPS Space Segment / Navigation User Interfaces Standard. ARINC Research Corporation; 2250 E. Imperial Highway; El Segundo, California 90245

### RTCM-SC-104

Recommended Standards For Differential GNSS Service. Radio Technical Commission For Maritime Services; 1800 N. Kent St, Suite 1060; Arlington, Virginia 22209

## CMR, CMR+

Compact Measurement Record; Trimble Navigation Limited; 935 Stewart Drive; Sunnyvale, CA 94085

## NMEA-0183

National Marine Electronics Association Standard For Interfacing Marine Electronic Devices. NMEA National Office; 7 Riggs Avenue; Severna Park, Maryland 21146

## Chapter 1 ..... Introduction

### System Overview

#### GPS Sensor System

The SF-2050 GPS sensor delivers unmatched accuracy to the precise positioning community. This unique receiver is designed to use NavCom's StarFire™<sup>1</sup>



network, which is a worldwide Satellite Based Augmentation System (SBAS) for decimeter level position accuracy (post-convergence period). The receiver is also capable of RTK<sup>2</sup>, RTCM (code and phase), and CMR/CMR+ DGPS operating methods. The operating software is also capable of supporting an external radio modem.

The SF-2050 integrated sensor consists of:

- ✓ 24-channel, dual-frequency, precision GPS receiver
- ✓ 2-channel WAAS/EGNOS SBAS receiver
- ✓ StarFire™ L-Band receiver<sup>1</sup>

There are three models, the SF-2050G, SF-2050M and the SF-2050R. Packaging and performance standards of the models are the same; the differences lie in the features, as described later in this chapter.

The system also includes a wide-band antenna with a built-in LNA (SF-2050R excluded) and other interconnection accessories outlined in Table 1, later in this chapter.

<sup>1</sup>Subscription Required; <sup>2</sup>Separate Software Option Required

## Accuracy

When WAAS or EGNOS correction signals are used, the system provides <50cm position accuracy.



WAAS signals are generated and controlled through the United States Federal Aviation Administration (FAA). EGNOS signals are generated and controlled through the European Space Agency. System accuracy with WAAS or EGNOS signals are subject to the quality and update rate of these government controlled signals.

The system provides <10cm position accuracy (post-<sup>2</sup>convergence period) when StarFire™ correction signals are used.

The system provides instant <1cm position accuracy when RTK<sup>1</sup> correction signals are used. (Short base-line, <10km, 1cm +1ppm)

## Features ... Applies to All Models

### Output Data Rate

Both SF-2050 models can output proprietary raw data at programmable rates from  $\leq 1\text{Hz}$  to predetermined rates up to  $50\text{Hz}$ <sup>1</sup> and Position Velocity Time (PVT) data at programmable rates from  $\leq 1\text{Hz}$  to predetermined rates up to  $25\text{Hz}$ <sup>1</sup> through two 115kbps RS-232 serial ports with less than 20ms latency.  $\leq 10\text{cm}$  horizontal and  $\leq 15\text{cm}$  vertical accuracy are maintained as each output is independently calculated based on an actual GPS position measurement, as opposed to an extrapolation/interpolation between 1Hz measurements.

<sup>1</sup>Separate Software Option Required; <sup>2</sup>See Glossary or Web-site

## NCT Binary Proprietary Data

The sensor can output proprietary raw data containing information including (but not limited to):

- ✓ Satellite Ephemeris (0x81)
- ✓ Satellite Almanac (0x44)
- ✓ Raw Pseudorange Measurements (0xB0)
- ✓ Position, Height, & Time (0xB1)
- ✓ Velocity & Heading (0xB1)
- ✓ Signal to Noise (0x86)
- ✓ Channel Status (0x86)
- ✓ Correction Data (mirror data; 0xEC)
- ✓ Event/Marker (M model only; 0xB4)
- ✓ Measurement Quality (0xB1 and 0xB5)

These data can be integrated in real-time positioning applications or post-processed against any number of software applications designed to handle NCT or RINEX raw data. A Technical Reference Manual is available on NavCom's web site, which describes the attributes of each of the input/output records (see *Related Documents* in the fore-matter).

## NMEA-0183 Data

The SF-2050 is capable of outputting several standard NMEA-0183 data strings (see *Related Standards* in the fore-matter) and one proprietary data string. Each data is headed with GP. The proprietary data string is denoted with a \$PNCT header.

**Standard:**

- ✓ ALM – GPS Almanac Data
- ✓ GGA – GPS Fix Data
- ✓ GLL – Geographic Position – Lat / Lon
- ✓ GSA – GNSS DOP & Active Satellites
- ✓ GST – GNSS Pseudorange Error Statistics
- ✓ GSV – GNSS Satellites In View
- ✓ RMC – Recommended Minimum Specific GNSS Data
- ✓ VTG – Course Over Ground & Ground Speed
- ✓ ZDA – Time & Date

**Proprietary (header \$PNCT):**

- ✓ SET – Solid Earth Tide  
Described in the *Technical Reference Manual* (see *Related Documents* in the fore-matter)

## Models

### SF-2050G

This model is designed for:

- ✓ Geographical Information System (GIS)
- ✓ Aerial Surveying (VueStar)
- ✓ Hydrographic Surveying
- ✓ Post-processed Dual-frequency Surveys
- ✓ Real-time Positioning Applications

The sensor can be carried in a backpack with the antenna either pole-mounted from the backpack or on a survey pole.

## SF-2050M

This model is ideal for vehicle mounting to suit a wide variety of machine guidance and control applications in:

- ✓ Agriculture
- ✓ Mining
- ✓ Aerial Surveying
- ✓ Hydrographic Surveying

It is equipped with additional features allowing interconnectivity with a wide variety of antennas, vehicle data busses and other instrumentation to suit specific applications and configurations. Features that distinguish this model include:

- ✓ A 1PPS output port
- ✓ A combined Event/CAN Bus interface port<sup>1</sup>
- ✓ A wide variety of antennas

## SF-2050R

This model is the same as the M model, except that it is designed for vehicle mounting with separate antennas for GPS/WAAS/EGNOS (PN: 82-001002-3002) and StarFire™ (PN: 82-001003-0001). The purpose of the separate antenna systems is to provide better low-elevation look angles to the StarFire™ signals in high-latitude locations.



The GPS antenna port provides 4.3VDC and the StarFire™ antenna port provides 5.0VDC. Care must be taken to select an appropriately rated GPS antenna if the standard NavCom antenna is not used.

<sup>1</sup>An Event latch interface may be necessary for mechanically devices (i.e. camera shutter)

## Antennae

### Standard

The standard integrated antenna (PN: 82-001002-3002) tracks all GPS, WAAS/EGNOS and StarFire™ signals. Our compact GPS antenna has excellent tracking performance and a stable phase center for GPS L1 and L2. This antenna is listed in the NOAA GPS Antenna Calibration tables, as NAVAN2004T. The robust housing assembly features a standard 5/8" BSW thread for mounting directly to a surveyor's pole, tripod, or mast and is certified to 70,000 feet (see *Specifications* for restrictions).



### Airborne (option)

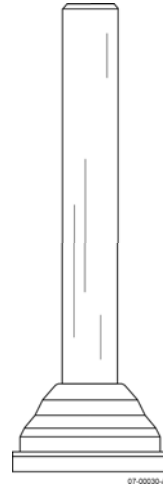
Included with the VueStar system.

The airborne integrated antenna (PN: 82-001002-3001) tracks all GPS, WAAS/EGNOS and StarFire™ signals. Our compact GPS antenna has excellent tracking performance and a stable phase center for GPS L1 and L2. This antenna is listed in the NOAA GPS Antenna Calibration tables, as NAVAN2008T. The robust housing assembly features a flat mounting surface with four mounting holes and a downward facing TNC connector. This antenna is also certified to 70,000 feet (see *Specifications* for restrictions).



## L-band (option – SF-2050R only)

The L-band antenna (PN: 82-001003-0001) tracks StarFire™ signals. This antenna has excellent tracking performance of geostationary satellites for latitudes furthest from the equator. The robust housing assembly features a flat mounting surface with two mounting holes and a 3m coaxial cable with an SMA and a TNC connector. A 5/8" surveyors mount is also available. The SF-2050R uses the SF-2050M GPS antenna to receive the GPS and WAAS/EGNOS signals.



## Controller

The SF-2050 GPS sensor is designed for use with an external controller solution connected via one of two serial COM ports.

This may be accomplished using a PC, Tablet PC or Personal Digital Assistant (PDA) and a software program which implements the rich control language defined for NavCom GPS products. Refer to the user's guide of your controller solution for further information. NavCom lists several application software solutions on our website:

<http://www.navcomtech.com/Support/ApplicationSoftware.cfm>

In addition, NavCom provides a Windows™ based software utility, called StarUtil, with the receiver.

The StarUtil User Guide, P/N 96-310008-3001, is available on-line at

<http://www.navcomtech.com/Support/DownloadCenter.cfm?category=manuals>.

## Included Items



*Figure 1: SF-2050 Supplied Equipment*

*Table 1: Supplied Equipment*

1	SF-2050 GPS Sensor (SF-2050G P/N 92-310056-3001) (SF-2050M P/N 92-310056-3002) (SF-2050R P/N 92-310056-3003)
2	LEMO 7-Pin to DB9S Data Cable, 6 ft (P/N 94-310059-3006)
3	Compact L1/L2 Tri-Mode GPS Antenna (P/N 82-001002-3002)
4	GPS Antenna Cable, 12 ft (P/N 94-310058-3012)
5	LEMO 4-Pin Universal AC/DC Power Adapter 12vdc, 2A (P/N 82-020002-5001)
6	CD-Rom containing User Guides, brochures, software utilities, and technical papers. (P/N 96-310006-3001)
7	SF-2050 User's Guide {Not Shown} (P/N 96-310002-3001 Hard Copy)
8	Ruggedized Travel Case {Not Shown} (P/N 79-100100-0002)
9	American 2-Pin AC power Cord, 10 ft {Not Shown}

## Applications

The SF-2050 GPS sensors meet the needs of a large number of applications including, but not limited to:

- ✓ Land Survey / GIS
- ✓ Asset Location
- ✓ Hydrographic Survey
- ✓ Photogrammetric Survey
- ✓ Machine Control
- ✓ Railway, Ship and Aircraft Precise Location

NavCom lists several application software solutions on our website:

<http://www.navcomtech.com/Support/ApplicationSoftware.cfm>

## Unique Features

The SF-2050 GPS sensor has many unique features:

### ■ StarFire™

The ability to receive NavCom's unique StarFire™ correction service is fully integrated within each unit (no additional equipment required). A single set of corrections can be used globally enabling a user to achieve decimeter level positioning accuracy without the need to deploy a separate base station, thus saving time and capital expenditure.

StarFire™ position outputs are referenced to the ITRF2000 datum.

### ■ Positioning Flexibility

The SF-2050 is capable of using two internal Satellite Based Augmentation System (SBAS) channels: Wide Area Augmentation System (WAAS) or European Geostationary Navigation Overlay Service (EGNOS) code corrections. The SF-2050 automatically

configures to use the most suitable correction source available and changes as the survey dictates (this feature can be overridden).

### ■ RTK Extend™

<sup>1</sup>RTK Extend™ enables continuous real-RTK/RTK level positioning accuracy during radio communication outages by utilizing NavCom's global StarFire™ corrections.

Traditionally, when an RTK rover loses communication with the base station, it is unable to continue to provide centimeter position updates for more than a few seconds, resulting in user down-time and reduced productivity. With RTK Extend™, a NavCom StarFire™ receiver operating in RTK mode, can transition to RTK Extend™ mode and maintain centimeter level positioning during communication loss for up to 15 minutes. RTK Extend™ allows more efficient and uninterrupted work, enabling focused concentration on the work rather than the tools.

### ■ Data Sampling

GPS L1 and L2 raw measurement data is up to 5Hz in the standard configuration. An optional upgrade allows 10, 25, and 50Hz raw measurement data via either of the two serial ports.

The PVT (Position, Velocity, & Time) data is output at up to 5 Hz in the standard configuration. An optional upgrade allows 10 and 25Hz position updates for highly dynamic applications.

### ■ GPS Performance

The SF-2050 utilizes NavCom's NCT-2100 GPS engine, which incorporates several patented innovations. The engine's industry leading receiver sensitivity provides more than 50% signal to noise

---

<sup>1</sup>Separate Software Option Required

ratio advantage over competing technologies. This results in improved real time positioning, proven through independent tests, when facing various multipath environments.

#### ■ Rugged Design

Units have been tested to conform to MIL-STD-810F for low pressure, solar radiation, rain, humidity, salt-fog, sand, and dust.

The rugged design of the SF-2050 system components provides protection against the harsh environments common to areas such as construction sites, offshore vessels, and mines.

This page is left blank intentionally

## Chapter 2 ..... Interfacing

This chapter details the SF-2050 GPS sensor connectors, LED display, appropriate sources of electrical power, and how to interface the communication ports.

### Electrical Power

A front panel 4-pin LEMO female connector provides electrical power to the SF-2050. Pin assignments are given in Table 2; see Figure 4 for pin location on the connector.

*Table 2: External Power Cable Pin-Out*

Pin	Description
1	Return
2	
3	Power Input 10 to 30 VDC; 8W
4	

Pins 1 and 2 connect to same internal point in the SF-2050. Likewise, pins 3 and 4 connect to the same internal point. The supplied power cable is constructed using 26 AWG wire.



Power cable longer than 5m (15ft) must make full use of all four power pins.

The SF-2050 is supplied with a universal AC/DC, 12V, 2A power adapter (P/N 82-020002-5001).



*Figure 2: Universal Power Adapter*



Replacement AC power cords are available through small appliance retailers (Radio Shack, Walmart, Best Buy, etc.)

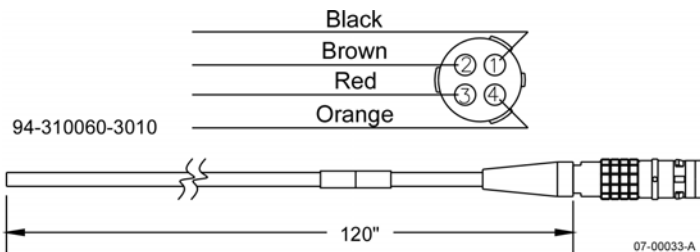


*Figure 3: AC Power Cord*

P/N 94-310060-3010 is an optional 10ft (3m) unterminated power cable fitted with a LEMO plug type (Mfr. P/N FGG.1K.304.CLAC50Z), with red strain relief. The wiring color code and pin assignments are labeled on the cable assembly and provided below.

*Table 3: Optional DC Power Cable Pin Assignments*

Color	Signal	Pin No
Black	Return	1
Brown		2
Red	Power	3
Orange		4



*Figure 4: Optional DC Power Cable*

The GPS sensor is protected from reverse polarity with an inline diode. It will operate on any DC voltage between 10 and 30 VDC, 8 watts (maximum).



Voltages less than 10VDC will turn the unit off. To turn the unit on, power must be in the 10 to 30 VDC range. Press and hold the I/O switch in for more than 3 seconds.

To set the receiver to power up as soon as power is applied to the DC Input port, refer to the *StarUtil Users Guide, Power Management* or the

*Technical Reference Manual, 0x32  
Power Mode Configuration.*



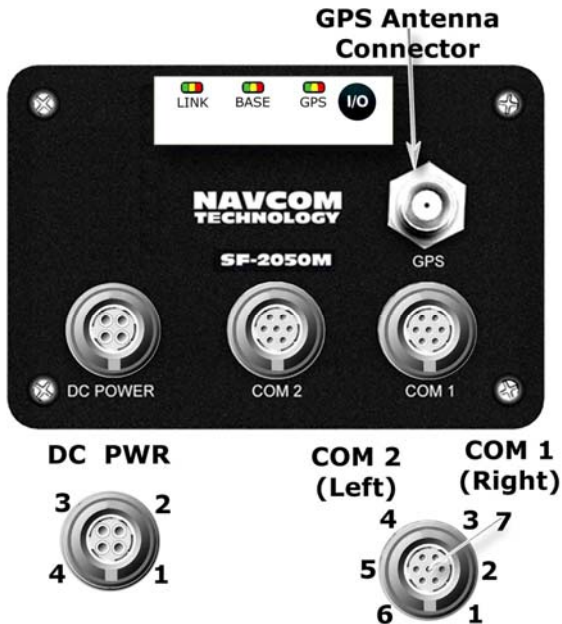
Voltages in excess of 30VDC will damage the unit. The power supply must be well conditioned with surge protection. Vehicular electrical systems which create voltage spikes in excess of 30VDC will benefit from providing power protection during vehicle engine power-up. This can be accomplished through a relay power-on sequence and/or power conditioning (such as a DC to DC converter). Do not connect equipment directly to the vehicles battery without in-line protection (such as a DC to DC converter).

## Communication Ports

The SF-2050 provides two 7-pin female LEMO connector communication ports labeled COM1 and COM2 located at the bottom front of the sensor, as shown in Figure 5. Each conforms to the EIA RS232 standard with data rates from 1.2 to 115.2kbps. The connector pin-outs are described in Table 4. The supplied interface data cable (P/N 94-310059-3006) is constructed as described in Figure 6. The SF-2050 is configured as a DCE device. Laptop and desktop computers are configured as DTE devices, therefore a straight-through cable provides proper connectivity (PC TXD pin 2 connects to SF-2050 RXD pin 2).

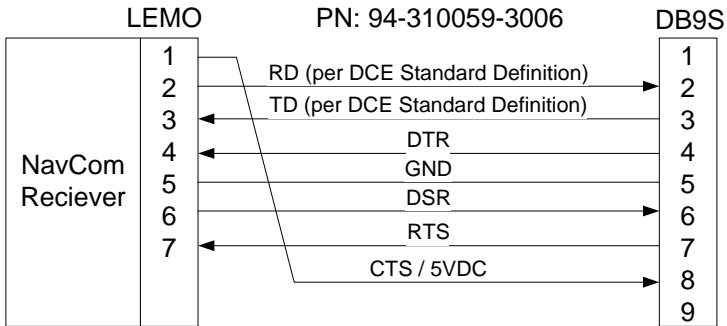
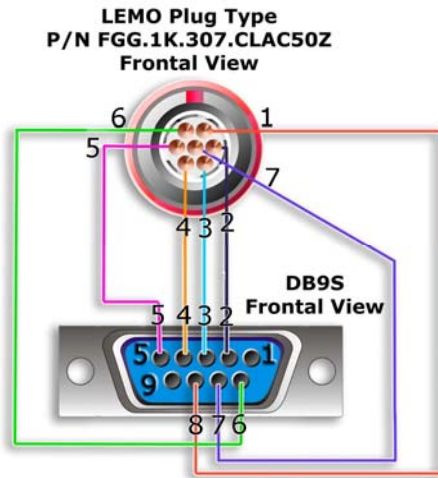
*Table 4: Serial Cable Pin-Outs*

<b>LEMO Pins</b>	<b>Signal Nomenclature [DCE w/respect to DB9]</b>	<b>DB9S Pins</b>
1	CTS - Clear To Send 5VDC to TruBlu <sup>1</sup>	8
2	RD - Receive Data	2
3	TD - Transmit Data	3
4	DTR - Data Terminal Ready	4
5	RTN - Return [Ground]	5
6	DSR - Data Set Ready	6
7	RTS - Request To Send	7



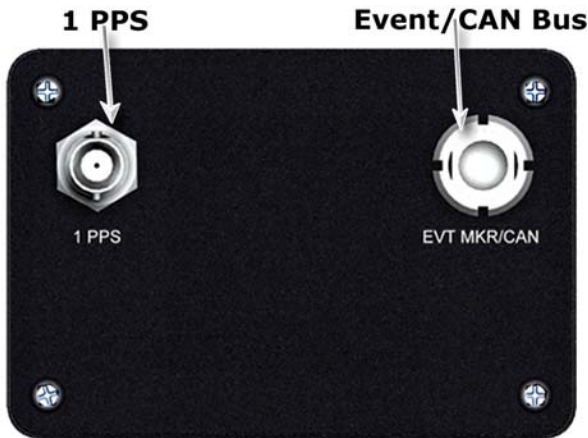
*Figure 5: SF-2050 Front View*

<sup>1</sup>TruBlu – NavCom’s Bluetooth wireless accessory



07-00039-A

*Figure 6: NavCom Serial Cable P/N 94-310059-3006*  
Connect pin 5 to shield of cable at both ends.



*Figure 7: SF-2050M Only Back View*

## CAN Bus/Event

The SF-2050M provides a balanced (differential) 2-wire CAN Bus technology interface, ISO11898 -24V compliant. The CAN interface uses an asynchronous transmission scheme employing serial binary interchange widely used in the automotive industry. The data rate is defined as 250Kbps maximum with termination resistors at each end of the cable. This port/connector is shared with the Event Input.



CAN Bus specifications are diverse. Drivers for the existing hardware must be tailored to the specific manufacturer's equipment being interfaced to. For further information, e-mail NavCom Customer Support at [customersupport@NavComtech.com](mailto:customersupport@NavComtech.com).

## Event

The SF-2050M accepts an event input pulse to synchronize external incidents requiring precise GPS time tagging, such as aerial photography. For

example, the action of a camera's aperture creates an input pulse to the Event port. The SF-2050M outputs position and time information relative to each photograph taken.

Specifications:

- ✓ 50 Ohm input impedance
- ✓ 3Vdc > Input Voltage, High < 6Vdc
- ✓ 0Vdc < Input Voltage, Low < 1.2Vdc
- ✓ Minimum pulse width, 100nsec
- ✓ Rising or Falling edge Synchronization

Connecting the shared EVT MKR/CAN BUS port requires a five core, 5mm diameter, cable fitted with a LEMO plug, type FGG.0K.305.CLAC50Z, plus strain relief, NavCom P/N 94-310062-3003.



An event latch interface unit may be necessary if the input device pulse is unable to drive the input.

Detailed specifications of the Event Input, cable wiring, and configuration may be found in Appendix D of this User Guide.

## 1 PPS

A pulse is available from the SF-2050M at an output rate of once per second. This pulse can be used for a variety of Time/ Mark applications where relative timing is required.

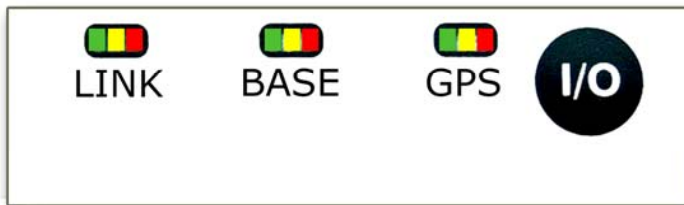
Specifications:

- ✓ 12.5ns relative accuracy
- ✓ Better than 100ns absolute accuracy
- ✓ 50 Ohm, TTL level
- ✓ Pulse width, default 100mS, range 10 – 999mS

- ✓ Pulse delay, default 0mS, range 0 – 999mS
- ✓ Rising or Falling Edge Synchronization

A BNC female connector provides the 1PPS output pulse. A 3ft (0.9m) long, BNC male to BNC male cable (P/N 94-310050-3003) is available from NavCom.

## Indicator Panel



*Figure 8: SF-2050 Indicator Panel*

The indicator panel provides a quick status view of the StarFire™ signal strength, base station correction type, GPS navigation/operating mode, and the On/Off (I/O) switch, respectively. Each set of indicators has three LEDs.








To power the unit on or off, depress the I/O switch for more than 3 seconds. All LEDs illuminate for a period of 3-5 seconds during power-up of the GPS sensor.

### ■ Link LEDs







The Link LEDs are software configurable via the x3f proprietary command. Only the factory default configuration is described here.

*Table 5: Link LED Indication (Default)*

<b>LINK</b>	<b>Status</b>
	Command Mode
  	Repeating Red to Amber to Green indicates Searching StarFire™ signal
	C/No >8dB - Strong Signal Strength from StarFire™
	C/No >4dB but <8dB - Medium Signal Strength StarFire™
	C/No <4dB - Weak Signal Strength StarFire™







#### ■ Base LEDs

*Table 6: Base Station Indication*

<b>BASE</b>	<b>Status</b>
	The BASE LEDs are not utilized in StarFire™ operating mode
The following BASE LEDs reflect the type of RTK corrections when the SF-2050 is operated as a Base Station	
	RTK - NCT Proprietary
	CMR
	RTCM, 20,21; 18,19

■ GPS LEDs

*Table 7: GPS Light Indication*

<b>GPS</b>	<b>Status</b>
	Power is off
	Power is on, No satellites tracked
	Tracking satellites, position not available yet
	Non-differential positioning
	Code based differential positioning
	Dual frequency Phase positioning



The *GPS* LEDs blink at the PVT positioning rate (1, 5, 10, or 25Hz)

This page is left blank intentionally


## Chapter 3 ..... Installation

This chapter provides guidance on hardware installation for optimum performance.

### Standard Antenna


The 5/8 inch BSW threaded antenna mount has a depth of 16mm (0.63 inch).

It is possible to remove the 5/8 inch BSW threaded alloy insert to reveal a secondary means of mounting the antenna, a 1-14UNS-2B thread with a depth of 16mm (0.63 inch). This is a typical marine industry mount for navigation antennas.

 The BSW insert is secured in-place with an adhesive, and its removal will change the shock and vibration sustainability characteristics of the antenna mount.



*Figure 9: Standard GPS/L-band Antenna*

 Do not loosen or remove the eight Phillips screws on the base of the antenna for mounting purposes. This will VOID the warranty and compromise the environmental seal of the antenna, leading to internal damage.

- 
- ✓ Antenna placement is critical to good system performance. Avoid antenna shading by buildings, rooftop structures, foliage, hills/mountains, etc.
  - ✓ Locate the antenna where it has a clear view of the sky, to an elevation angle of  $7^{\circ}$  if possible. Obstructions below  $15^{\circ}$  elevation generally are not a problem, though this is dependent on satellite availability for the local region.
  - ✓ Avoid placing the antenna where more than  $90^{\circ}$  azimuth of the sky is obstructed. When more than  $90^{\circ}$  of azimuth is shaded, it is often still possible for the receiver to navigate, however, poor satellite geometry (due to satellite shading) will provide poor positioning results. Even  $10^{\circ}$  of shading can have a negative effect on performance, though this generally is not the case.
  - ✓ Avoid placing the antenna on or near metal or other electrically reflective surfaces.
  - ✓ Do not paint the antenna enclosure with a metallic-based paint.
  - ✓ Avoid placing the antenna near electrical motors (elevator, air conditioner, compressor, etc.)
  - ✓ Do not place the antenna too close to other active antennas. The wavelength of L2 is 0.244m and L1 is 0.19m. The minimum acceptable separation between antennas is 1m (39 in), which provides 6dB of isolation. For 10 dB of isolation, separate the GPS antennas by 2.5m, and for 13dB of isolation (recommended) separate the antennas by 5m.
  - ✓ Active antennas (those with LNA's or amplifiers) create an electrical field around the antenna. These radiated emissions can interfere with other nearby antennas. Multiple GPS antennas in close

proximity to each other can create multipath and oscillations between the antennas. These add to position error or the inability to process the satellite signals.

- ✓ Most antenna's have better gain when the satellite is high in elevation. Expect tracking performance to fade as the satellite lowers in elevation. It is not unusual to see 10dB difference in antenna gain (which translates into signal strength) throughout the entire elevation tracking path.
- ✓ Map obstructions above the horizon using a compass and inclinometer. Use satellite prediction software with a recent satellite almanac to assess the impact on satellite visibility at that location (available on NavCom's web site).
- ✓ A clear line of sight between the antenna and the local INMARSAT satellite is required to track the StarFire™ signal. INMARSAT satellites are geosynchronized 35,768kms above the Equator, currently at Longitudes 098° West, 025° East, and 109° East. An inclination and bearing estimation tool is available on NavCom's website to aid in determining potential obstructions to StarFire™ signal.

### L-Band Antenna (SF-2050R Only)

The separate L-band antenna for the SF-2050R is used in high latitude applications and most frequently on marine vessels. This is an active antenna, meaning has a built-in LNA. Therefore, this antenna should have good isolation from other near-frequency antennae. The best practice is to follow the same precautions as the standard GPS antenna. On platforms with many antenna systems, it is better to locate the standard GPS antenna closer to the wheelhouse, but out of the radar or satcom beam

path and the L-band antenna high on the mast. For best performance, do not allow more than 7dB of cable loss between the antenna and the receiver. Applications without the L-band antenna and operating at high latitudes should mount the GPS antenna high on the mast, with the same considerations for beam path avoidance and cable loss limitations.

## GPS Sensor

Mount the SF-2050 GPS sensor to a flat surface. Shock isolators suitable for 1.8kg (4lbs) may be necessary for environments with high vibration, i.e. Earth moving equipment or aircraft installation.

The SF-2050G can be installed in a backpack for mobile surveying applications.

Do not place the sensor be in a confined space or where it may be exposed to excessive heat, moisture, or humidity.



There are no user serviceable parts inside the SF-2050 GPS sensor. Removing the screws that secure the front end and rear end plates will void the equipment warranty.

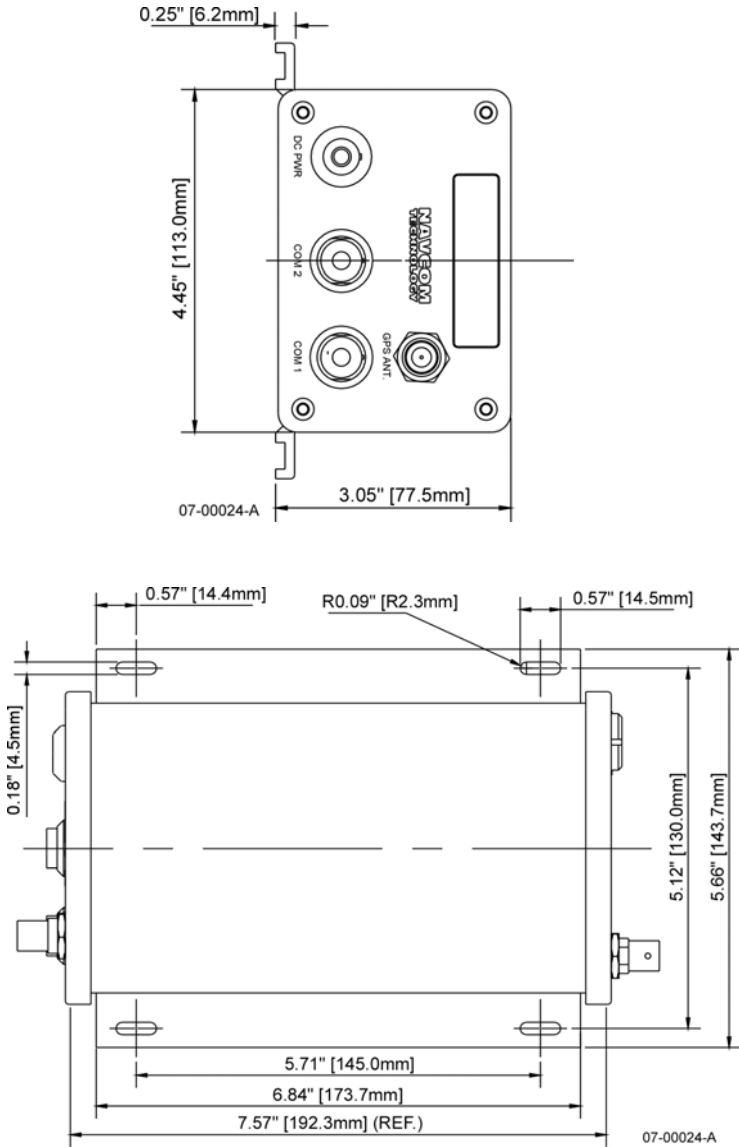
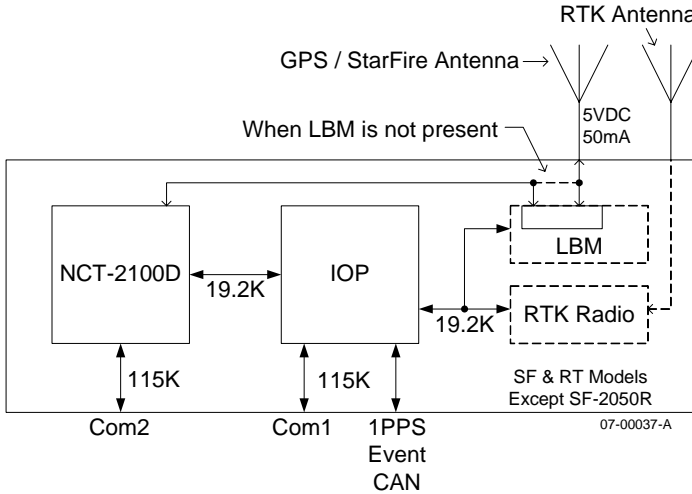


Figure 10: SF-2050 Base Plate Dimensions

## Block Diagrams

The SF-2050 has three user configurable physical communications ports (two external and one internal) and several logical communications ports. To aid in distinguishing these ports, please refer to the block diagrams below.



*Figure 11: SF-2050G/M Block Diagram*



These user configurable physical ports are Com1, Com2, and Radio/Diagnostic. The Com ports are described in the next section. The Radio/Diagnostic port connects to an internal UHF radio in NavCom's RT-line of products and is not used, nor should it be assigned as a logical port in any of the SF-2050 products.

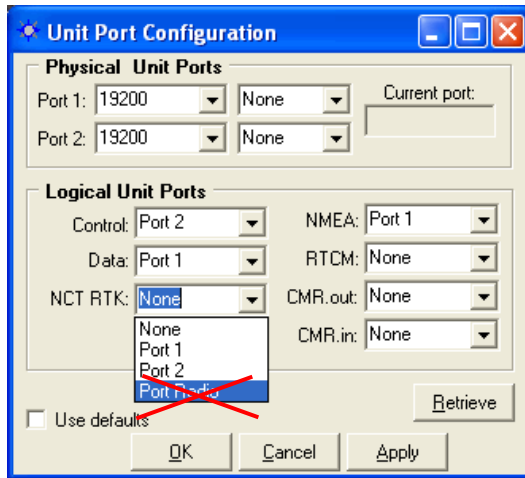


Figure 12: Radio Port Configuration, StarUtil

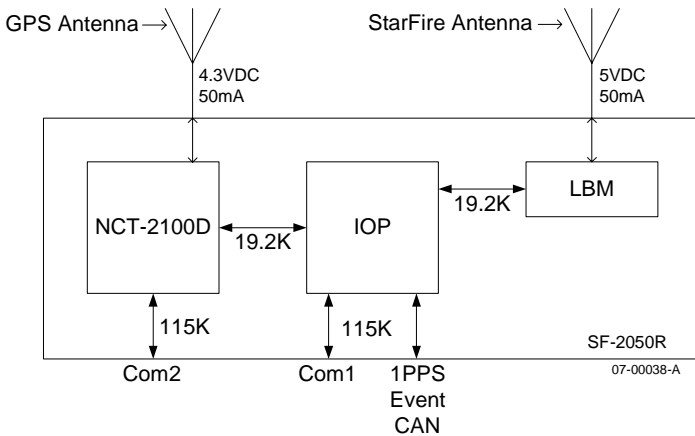


Figure 13: SF-2050R Block Diagram

---

## Communication Port Connectivity

Connect the supplied LEMO 7-Pin connector of the serial cable (P/N 94-310059-3006) to COM 2 (factory default Control Port) of the SF-2050. Connect the DB9 end to the control device.



Some devices may require an additional adapter. The receiver is configured as a DCE device.



COM 2 is the SF-2050 logical control port by default. COM 1 can be configured as the control port by using the appropriate NavCom proprietary commands or StarUtil. However, there are caveats to Logical / Physical port assignments.

The Control Port is a logical input/output port and can not share the physical port with any other logical port. The Control Port typically handles the most data and requires baud rates in excess of 19.2K baud, particularly in multi-hertz measurement and navigation applications. Though Com 1 is physically capable of operating at 115K baud, the throughput from the NCT-2100D to the IOP is limited to 19.2K baud (refer to Figure 11). Thus, the recommendation to maintain Com 2 as the Control port for multi-hertz applications.

In the Rover, the NMEA Port is an output logical port and may share the data physical port (non-Control) with RTCM, CMR, or NCT RTK input corrections. In the Base Station, the NMEA port can not share the data port with any RTCM, CMR, or NCT RTK output corrections.

Refer to the *Technical Reference Manual* for available port configuration settings.



Figure 14: Communication Port Connections

## GPS Antenna Connector

The connector used on the SF-2050 is a TNC female, labeled *GPS* on the front panel of the sensor as shown in Figure 5.



The SF-2050M and SF-2050G GPS connector provides 5 VDC, 50mA max power the antenna preamplifier. The SF-2050-R GPS connector provides 4.25 to 4.75 VDC, 50mA max power the GPS antenna preamplifier, and the StarFire™ connector provides 5.0 VDC, 50mA max power the StarFire™ only antenna preamplifier. Do not disconnect the antenna when the GPS unit is powered on.

The system is supplied with 12ft (3.6m) of RG58/U cable (P/N 94-310058-3012). The cable is fitted with

a right angle male TNC connector and a straight male TNC connector respectively.

The cable length between the antenna and SF-2050 should not exceed 7dB loss at 1.575GHz for optimum performance, though the system may tolerate up to 10dB of cable loss with minimal performance. Lower elevation satellite tracking suffers the most with more than 7dB insertion loss.

*Table 8: Acceptable Cable Lengths*

Cable Type	Atten. (dB) per 100 Ft.	Cable Length in Feet	Loss in dB	Atten. (dB) per 100 m	Cable Length in Meters	Loss in dB
RG-58C	19.605	36.00	7.06	64.32	11.00	7.08
RG-142	16.494	43.00	7.09	54.12	13.00	7.04
RG-213	9.564	74.00	7.08	31.38	22.50	7.06
RG-223	17.224	41.00	7.06	56.51	12.50	7.06
LMR600	3.407	207.00	7.05	11.18	63.00	7.04
LMR400	5.262	133.00	7.00	17.26	41.00	7.08
LMR240	10.127	70.00	7.09	33.23	21.00	6.98
LMR195	14.902	47.00	7.00	48.89	14.00	6.85

In-line amplifiers suitable for all GPS frequencies may be used to increase the length of the antenna cable, but care should be exercised that tracking performance is not degraded due to multiple connections, noise from the amplifier, and possible ingress of moisture and dust to the in-line amplifier. In-line amplifier or splitter devices must pass DC power from the receiver to the antenna, or source the appropriate voltage and current to the antenna (see *Antenna Specifications*). In-line amplifiers may also over-saturate the receiver front-end if improperly used.



The antenna cable can degrade signal quality if incorrectly installed, or the cable loss exceeds NavCom specifications.

Take care not to kink, stretch, distort, or damage the antenna cable. Do not place the cable adjacent to cables carrying electrical power or radio frequencies. In these instances, attempt to cross cables at 90° angles in an effort to reduce cross-coupling of RF signals.



Where the GPS antenna is exposed to sources of electromagnetic discharge such as lightning, install a properly grounded in-line electrical surge suppressor between the GPS sensor and antenna. Install protective devices in compliance with local regulatory codes and practices. Protective devices must pass DC power from the receiver to the antenna.

This page is left blank intentionally

---

## Chapter 4 ..... Configuration

The SF-2050 has a rich interface and detailed control language, allowing each unit to be individually tailored to a specific application.

There are essentially 3 methods available to configure and control the SF-2050:

- ✓ StarUtil – This program is a NavCom developed utility designed to configure and view many (but not all) of the SF-2050 functions. In addition to its setup capabilities, StarUtil can capture and log data, upload new software and licenses to the three internal processors, and query and display various receiver performance functions. Though it is developed as an Engineering tool, it has its own place in the commercial market as well. The program is provided on the CD with the SF-2050.
- ✓ 3<sup>rd</sup> part controller – Some manufacturers have already integrated NavCom's control features in their bundled hardware and software solution kits in a variety of applications including GIS, Machine Control, Aerial Photogrammetry, Land & Oceanographic Survey, Agriculture, and Military products. Information on these applications is available from the NavCom web site and customer service.
- ✓ User Program – User's may develop unique operating programs to control the SF-2050 (potentially in conjunction with other devices or utilities). To facilitate this effort, NavCom has two tools additional tools available: the Integrators Tool Kit (ITK) and the Technical Reference Manual (TRM). Information on these tools is available from the NavCom web site and customer service.

## Factory Default Settings

### ■ COM1

- ✓ Configuration - Data port
- ✓ Rate – 19.2Kbps
- ✓ Output of NMEA messages GGA & VTG scheduled @ 1Hz rate



Though the output rate defaults to 1Hz, the data output rate can be changed to *On Change*. Making this selection in the NMEA output list will better reflect the navigation rate selected in the Rover Setup screen.

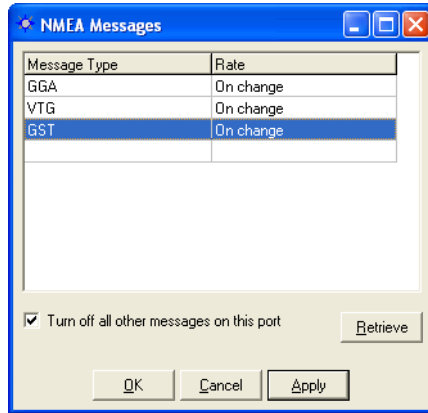
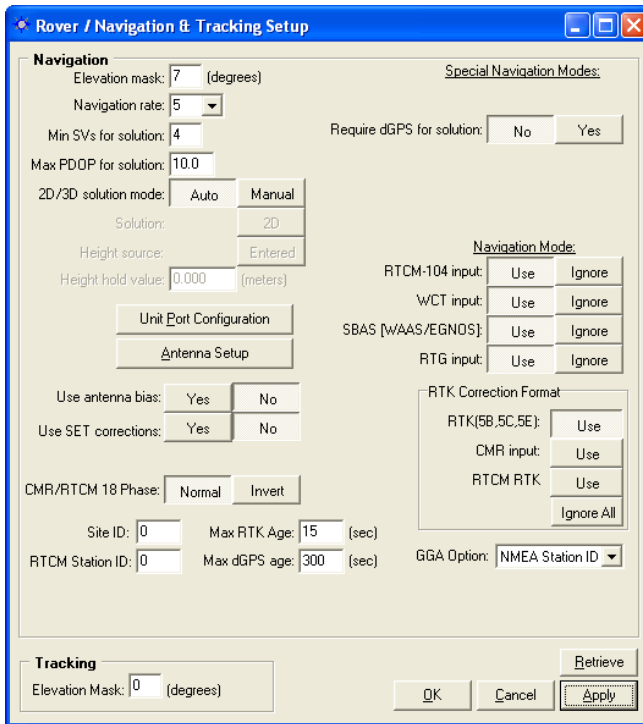


Figure 15: StarUtil NMEA Message List



*Figure 16: StarUtil Rover Navigation Setup*

This port is normally used to output data to other devices or machines that can make immediate use of the precise positioning data available from the SF-2050. COM1 also serves as the DGPS correction input/output port when NCT, CMR, or RTCM RTK correction services are in use.

■ **COM2**

- ✓ Configuration - Control Port
- ✓ Rate – 19.2Kbps

This port is normally used to input and output proprietary messages used for navigation and receiver setup. Table 9 describes the default messages needed to best initiate surveying with minimal effort.

The user has full control over the utilized message types and their associated rates via either StarUtil or a third party software/utility.

*Table 9: Factory Setup Proprietary Messages COM 2*

Msg	Rate	Description
44	On Change	Almanac
81	On Change	Ephemeris
86	On Change	Channel Status
A0	On Change	Alert Message
AE	600 Seconds	Identification Block
B0	On Change	Raw Measurement Data
B1	On Change	PVT Solution



The term “On Change” indicates that the SF-2050 will output the specified message only when the information in the message changes. On occasion, there may be an epoch without a message block output.

## Message Descriptions

The following message descriptions are fully defined in the Technical Reference Manual (see *Related Documents*)

- ✓ 44 Packed Almanac:  
Data corresponding to each satellite in the GPS constellation, including: GPS Week number of collected almanac, GPS Time of week [in seconds] of collected almanac, almanac reference week, almanac reference time, almanac source, almanac health, pages 1-25, and sub-frames 4 and 5.

- ✓ 81 Packed Ephemeris:  
Individual satellite tracking information including:  
GPS Week number of collected ephemeris, GPS  
Time of week [in seconds] of collected  
ephemeris, IODC, and sub-frame 1, 2, and 3  
data.
- ✓ 86 Channel Status:  
Receiver channel status information containing:  
the GPS week, GPS Time of Week, NCT-2100  
Engine status, number of satellites  
viewed/tracked, PDOP, tracked satellite identity,  
satellite elevation and azimuth, C/No for the L1  
and L2 signals, and correction age for each  
satellite.
- ✓ A0 Alert Text Message:  
Details message receipt and processing.
- ✓ AE Identification Block:  
Details the receiver software versions (NCT-  
2100, and IOP) and digital serial numbers.
- ✓ B0 Raw Measurement Data:  
Raw Measurement Data Block containing: the  
GPS Week, GPS Time of Week, Time Slew  
Indicator, Status, Channel Status, CA  
Pseudorange, L1 Phase, P1-CA Pseudorange,  
P2-CA Pseudorange, and L2 Phase. This data  
stream is repeated for each individual tracked  
satellite.
- ✓ B1 PVT (Position, Velocity, and Time):  
Provides: GPS Week number, satellites used,  
latitude, longitude, navigation mode, and DOP  
information.

### 3<sup>rd</sup> Party Controller Configuration Settings

Please refer to the third party controller solution manual/user guide if your SF-2050 GPS sensor is part of an integrated solution.

---

This page is left blank intentionally

## Chapter 5 ..... Safety Instructions

The SF-2050 GPS sensor is designed for precise navigation and positioning using the Global Positioning System. Users must be familiar with the use of portable GPS equipment, the limitations thereof and these safety instructions prior to use of this equipment.

### Transport

Always carry the NavCom equipment in its case. The case must be secured during transport to minimize shock and vibration.

Utilize all original packaging when transporting via rail, ship, or air.

### Maintenance

The NavCom equipment may be cleaned using a new lint free cloth moistened with pure alcohol.

Connectors must be inspected, and if necessary cleaned before use. Always use the provided connector protective caps to minimize moisture and dirt ingress.

Inspect cables regularly for kinks and cuts as these may cause interference and equipment failure.

Damp equipment must be dried at a temperature less than +40°C (104°F), but greater than 5°C (41°F) at the earliest opportunity.

### External Power Source

The SF-2050 is supplied with an external power cable (P/N 94-310060-3010). This must be connected to the chosen external power solution in accordance with Chapter 2 Interfacing\Electrical Power. It is important that the external power source allow

sufficient current draw for proper operation. Insufficient supplied current will cause damage to your external power source.

If your chosen external power source is a disposable battery, please dispose of the battery in accordance with your local regulations.

## Safety First

The owner of this equipment must ensure that all users are properly trained prior to using the equipment and are aware of the potential hazards and how to avoid them.

Other manufacturer's equipment must be used in accordance with the safety instructions issued by that manufacturer. This includes other manufacturer's equipment that may be attached to NavCom Technology, Inc. manufactured equipment.

Always use the equipment in accordance with local regulatory practices for safety and health at work.

There are no user serviceable parts inside the SF-2050 GPS sensor. Accessing the inside of the equipment will void the equipment warranty.

Take care to ensure the SF-2050 does not come into contact with electrical power installations, the unit is securely fastened and there is protection against electromagnetic discharge in accordance with local regulations.

---

## A..... GPS Module Specifications

The technical specifications of this unit are detailed below. NavCom Technology, Inc. is constantly improving, and updating our technology. For the latest technical specifications for all products go to: <http://www.navcomtech.com/Support/>

These GPS sensors are fitted with an internal Lithium coin cell battery used to maintain GPS time when power is removed from the unit. This allows faster satellite acquisition upon unit power up. The cell has been designed to meet over 10 years of service life before requiring replacement at a NavCom approved maintenance facility.

### Features

- ✓ “All-in-view” tracking with 26 channels (12 L1 GPS + 12 L2 GPS + 2 SBAS)
- ✓ Global decimeter-level accuracy using StarFire™ corrections
- ✓ Fully automatic acquisition of satellite broadcast corrections
- ✓ Rugged and lightweight package for mobile applications
- ✓ Accepts external DGPS input in RTCM v3.0 or CMR format
- ✓ L1 & L2 full wavelength carrier tracking
- ✓ C/A, P1 & P2 code tracking
- ✓ User programmable output rates
- ✓ Minimal data latency
- ✓ 2 separate WAAS/EGNOS channels
- ✓ Superior interference suppression

- ✓ Patented multipath rejection
- ✓ Output of NMEA 0183 v3.1 messages
- ✓ Self-survey mode (position averaging)
- ✓ CAN bus interface (SF-2050M Only)
- ✓ 1PPS Output (SF-2050M Only)
- ✓ Event Marker (SF-2050M Only)

## Time-To-First-Fix

Cold Start Satellite Acquisition	<p>&lt; 60 Seconds (typical; with Almanac)</p> <p>&lt; 5 minutes (typical; without Almanac)</p>
Satellite Reacquisition	<p>&lt; 6 seconds outage time; immediate reacquisition (&lt; 1 second)</p> <p>&lt; 30 seconds software, typical; with outage time &lt; 65 seconds</p> <p>&gt; 65 outage time requires full acquisition process</p>

## Dynamics

Acceleration:	up to 6g
Speed:	< 515 m/s*
Altitude:	< 60,000 ft*

\*Restricted by export laws

## Measurement Performance

<b>Real-time StarFire™ SBAS Accuracy</b>	
Position (H):	<10 cm
Position (V):	<15 cm
Velocity:	0.01 m/s
<b>Real-time WAAS SBAS Accuracy</b>	
Position (H):	<0.5 m
Position (V):	<0.7 m
Velocity:	0.01 m/s
<b>Code Differential GPS &lt;200km (RMS)</b>	
Position (H):	<12 cm +2ppm
Position (V):	<25 cm +2ppm
Velocity:	0.01 m/s
<b>RTK Positioning &lt;10km (RMS)</b>	
Position (H):	<1 cm +1ppm
Position (V):	<2 cm +ppm
Velocity:	0.01 m/s
<b>RTK Extend &lt;10km (RMS)</b>	
Position (H):	<2 cm +1ppm
Position (V):	<4 cm +ppm
Velocity:	0.01 m/s
<b>Pseudo-range Measurement Precision (RMS)</b>	
Raw C/A code :	20cm @ 42 dB-Hz
Raw carrier phase	L1: 0.95 mm @ 42 dB-Hz
noise:	L2: 0.85 mm @ 42 dB-Hz

## User programmable output rates

SF-2050G	
PVT	1, 2, 5Hz Standard 10 & 25Hz Optional
Raw data	1, 2, 5Hz Standard 10, 25, & 50Hz Optional
SF-2050M	
PVT	1, 2, 5, 10Hz Standard 25Hz Optional
Raw data	1, 2, 5, 10, 25Hz Standard 50Hz Optional

## Data Latency

PVT	< 20 ms at all nav rates
Raw data	< 20 ms at all rates

## 1PPS

Accuracy:	12.5ns (Relative; User Configurable); (SF-2050M Only)
-----------	---

## Connector Assignments

Data Interfaces:	
2 serial ports	from 1200 bps to 115.2 kbps
CAN Bus I/F	SF-2050M Only
Event Marker I/P	SF-2050M Only
1PPS	SF-2050M Only

## Input/Output Data Messages

NCT Proprietary Data	PVT , Raw Measurement Satellite Messages Nav Quality Receiver Commands
NMEA-0183 Messages (Output Only)	ALM, GGA, GLL, GSA, GST, GSV, RMC, VTG, ZDA
Proprietary NMEA-0183 Type (Output Only)	SET
Code Corrections	RTCM 1 or 9 WAAS/EGNOS StarFire™ (WCT)
RTK Correction Data (I/O)	NCT Proprietary StarFire™ (RTG Dual) RTCM 18,19 or 20, 21 CMR+/CMR (Msg. 0, 1, 2)



RTK data only available in SF-Series receivers optioned for RTK operation.



See *Related Standards* at the front of this manual for information on the various data formats

## LED Display Functions (Default)

Link	StarFire™ Signal Strength (Default; User Programmable)
Base Station	N/A in Standard SF-2050 Configuration (User Programmable)
GPS	Position Quality

## Satellite Based Augmentation System Signals

WAAS/EGNOS
StarFire™

### Physical and Environmental

Size (L x W x H):	< 8.18" x 5.67" x 3.06"
Weight:	<4 lbs (1.81 kg)
External Power: Input Voltage: Consumption:	10 VDC to 30 VDC 8 W
Connectors: I/O Ports: DC Power: RF Connector:	2 x 7 pin Lemo 4 pin Lemo TNC
Antenna Power	5 VDC, 0.05mA bias for LNA
Temperature (ambient) Operating Storage:	-40° C to +55° C -40° C to +85° C
Humidity:	95% non-condensing

## B..... Antenna Specifications

*Table B1: Standard Antenna*

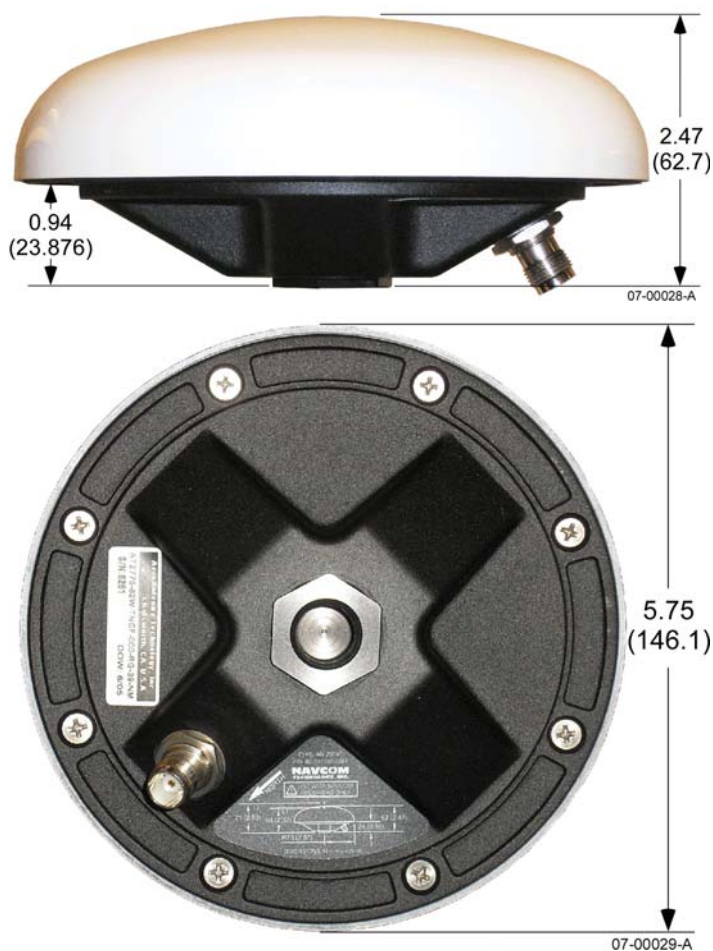
Part Number	82-001002-3002
Frequency	1525-1585 MHz GPS L1 plus INMARSAT StarFire™ 1217-1237 MHz GPS L2
L1 Phase Centre	58.7mm
Polarization	Right Hand Circular (RHCP)
Pre-Amplifier	39dB gain (+/-2dB)
Noise Figure	<2.5dB
Impedance	50 Ohms
VSWR / RL	≤ 2.0:1 / 9.54 dB min.
Band Rejection	20 dB @ 250MHz
RF Power Handling	1 Watt
Input Voltage	4.2 to 15.0 VDC
Power Consumption	0.3W 60mA ±10mA @ 5VDC
Cable Connector	TNC Female
Operating Temp	-55°C to +85°C
Altitude	70,000ft; 21,336m
Finish	Fluid resistant Ultem, UV stable



NavCom P/N 82-001002-3001 is an optional aircraft mount antenna, also rated to 70,000 feet (21,336m).



Designed to DO-160D Standard



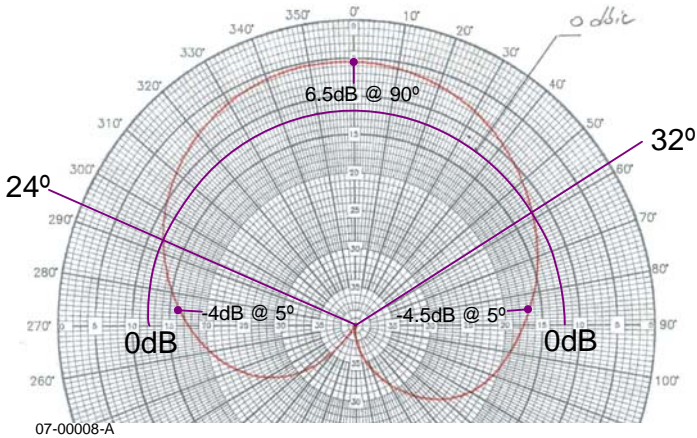
*Figure B1: PN: 82-001002-3002 Antenna Dimensions*



To achieve the greatest level of accuracy, the absolute phase center values must be incorporated into your processing. Phase center information on this antenna is found on our web site:

<http://www.navcomtech.com/Support/DownloadCenter.cfm?category=antenna>

## Radiation Pattern



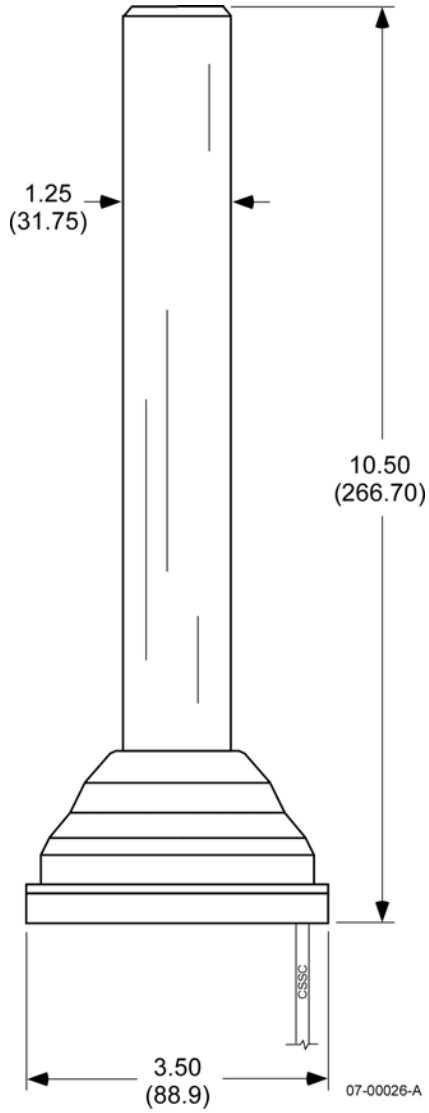
*Figure B2: AN-2004T Radiation Pattern*

Optimal antenna performance is realized at elevations greater than 30°.

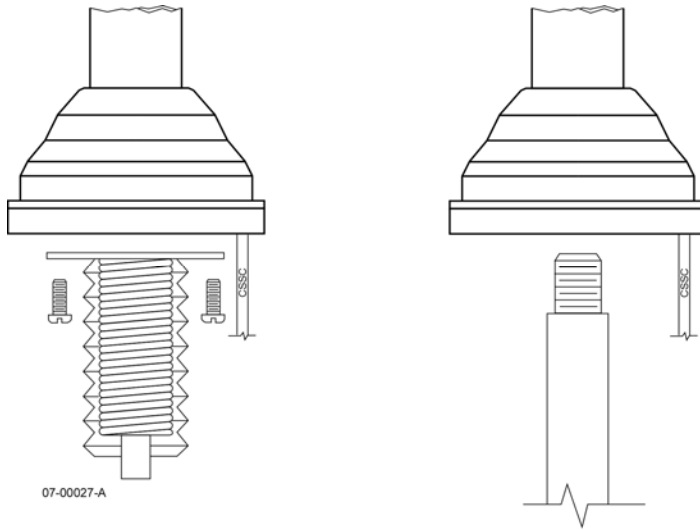
- ☐ There is a 10dB variation between 0° and 90° elevation (factor 10x); therefore, lower elevation satellites are always more difficult to track.
- ☐ There is a 5dB variation between ~35° and 0° elevation (factor >3x)

*Table B2: L-band SF-2050R Antenna*

Part Number	82-001003-001
Frequency	1525-1585 MHz INMARSAT StarFire™
Polarization	Right Hand Circular (RHCP)
Pre-Amplifier	25dB gain min. (to coax end)
Noise Figure	1.0dB typical
Impedance	50 Ohms
Input Voltage	3.0 to 5.5 VDC
Power Consumption	0.3W typical 8.5mA $\pm$ 10mA @ 3.6VDC
Cable Connector	TNC Female
Cable Length	3 meters
Operating Temp	-55°C to +85°C
Magnetic attachment shear strength	3Kg Typical
Direct attachment force pull	4Kg Typical
The quadrafilar antenna wind loading	200Km/hr.
Minimum break-over force (foliage brushing)	10Kgm

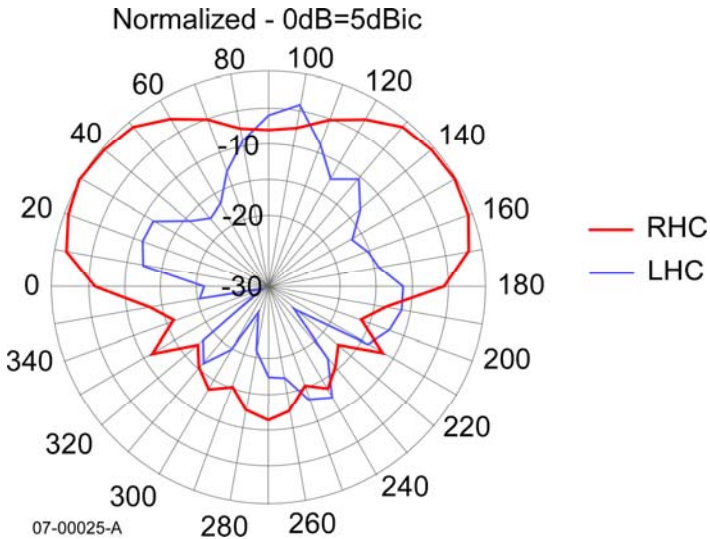


*Figure B3: PN: 82-001003-0001 Antenna Dimensions*



*Figure B4: PN: 82-001003-001 Mounts*

## Radiation Pattern



*Figure B5: AN-2001L Radiation Pattern*

Optimal antenna performance is realized at elevations between  $10^{\circ}$  and  $50^{\circ}$ .



There is an 8dB variation between  $40^{\circ}$  and  $90^{\circ}$  elevation (factor 6.3x); therefore, higher elevation satellites are always more difficult to track.

There is a 3dB variation between  $10^{\circ}$  and  $0^{\circ}$  elevation (factor >2x)

This page is left blank intentionally

C ..... StarFire™



**Description**

The StarFire™ Network is a global system for the distribution of SBAS corrections giving the user the ability to measure his position anywhere in the world with exceptional reliability and unprecedented accuracy of better than 10cm (4 inches). Because the SBAS corrections are broadcast via INMARSAT geostationary satellites, the user needs no local reference stations or post-processing to get this exceptional accuracy. Furthermore, the same accuracy is available virtually any where on the earth's surface on land or sea from 76°N to 76°S latitude, due to the worldwide coverage of these geostationary satellites.

## Infrastructure

The system utilizes the GPS satellite system, L-Band communication satellites, and a worldwide network of reference stations to deliver real-time high precision positioning.

To provide this unique service, NavCom has built a global network of dual-frequency reference stations, which constantly receive signals from the GPS satellites as they orbit the earth. Data from these reference stations is fed to two USA processing centers in Torrance, California and Moline, Illinois where they are processed to generate the differential corrections.

From the two processing centers, the correction data is fed via redundant and independent communication links to satellite uplink stations at Laurentides, Canada; Goonhilly, England; and Auckland, New Zealand for rebroadcast via the geo-stationary satellites.

The key to the accuracy and convenience of the StarFire™ system is the source of SBAS corrections. GPS satellites transmit navigation data on two L-Band frequencies. The StarFire™ reference stations are all equipped with geodetic-quality, dual-frequency receivers. These reference receivers decode GPS signals and send precise, high quality, dual-frequency pseudorange and carrier phase measurements back to the processing centers together with the data messages, which all GPS satellites broadcast.

At the processing centers, NavCom's proprietary differential processing techniques used to generate real time precise orbits and clock correction data for each satellite in the GPS constellation. This proprietary Wide Area DGPS (WADGPS) algorithm is optimized for a dual-frequency system such as StarFire™ in which dual-frequency ionospheric

measurements are available at both the reference receivers and the user receivers. It is the use of dual-frequency receivers at both the reference stations and the user equipment together with the advanced processing algorithms, which makes the exceptional accuracy of the StarFire™ system possible.

Creating the corrections is just the first part. From our two processing centers, the differential corrections are then sent to the Land Earth Station (LES) for uplink to L-Band communications satellites. The uplink sites for the network are equipped with NavCom-built modulation equipment, which interfaces to the satellite system transmitter and uplinks the correction data stream to the satellite that broadcasts it over the coverage area. Each L-Band satellite covers more than a third of the earth.

Users equipped with a StarFire™ precision GPS receiver actually have two receivers in a single package, a GPS receiver and an L-Band communications receiver, both designed by NavCom for this system. The GPS receiver tracks all the satellites in view and makes pseudorange measurements to the GPS satellites. Simultaneously, the L-Band receiver receives the correction messages broadcast via the L-Band satellite. When the corrections are applied to the GPS measurements, a position measurement of unprecedented real time accuracy is produced.

## Reliability

The entire system meets or exceeds a target availability of 99.99%. To achieve this, every part of the infrastructure has a built-in back-up system.

All the reference stations are built with duplicate receivers, processors and communication interfaces, which switch automatically or in response to a remote control signal from the processing centers. The data

---

links from the reference stations use the Internet as the primary data link and are backed up by dedicated communications lines, but in fact the network is sufficiently dense that the reference stations effectively act as back up for each other. If one or several fail, the net effect on the correction accuracy is not impaired.

There are two continuously running processing centers, each receiving all of the reference site inputs and each with redundant communications links to the uplink LES. The LESs are equipped with two complete and continuously operating sets of uplink equipment arbitrated by an automatic fail over switch. Finally, a comprehensive team of support engineers maintains round the clock monitoring and control of the system.

The network is a fully automated self-monitoring system. To ensure overall system integrity, an independent integrity monitor receiver, similar to a standard StarFire™ user receiver, is installed at every reference station to monitor service quality. Data from these integrity monitors is sent to the two independent processing hubs in Torrance, California and Moline, Illinois. Through these integrity monitors the network is continuously checked for overall SBAS positioning accuracy, L-Band signal strength, data integrity and other essential operational parameters.

## How to Access the StarFire™ Service

StarFire™ is a subscription service. The user pays a subscription, which licenses the use of the service for a predetermined period of time.

Subscriptions can be purchased for quarterly, biannual or annual periods and are available via a

NavCom authorized representative, or by contacting [NavCom Sales Department](#).

An authorized subscription will provide an encrypted keyword, which is specific to the Serial Number of the NavCom receiver to be authorized. This is entered into the receiver using the provided controller solution. Typically the initial license is preinstalled at the factory, and subsequent licenses will be installed by the user.

The only piece of equipment needed to use the StarFire™ system is a StarFire™ receiver. NavCom offers a variety of receivers configured for different applications. Details of all the StarFire™ receivers are available from the NavCom authorized local representative or the NavCom website at: [www.NavComtech.com](http://www.NavComtech.com)

StarFire™ receivers include a dual-frequency GPS receiver and an L-Band receiver integrated into a single unit to provide the exceptional precise positioning capability of the StarFire™ Network, anywhere, anytime.

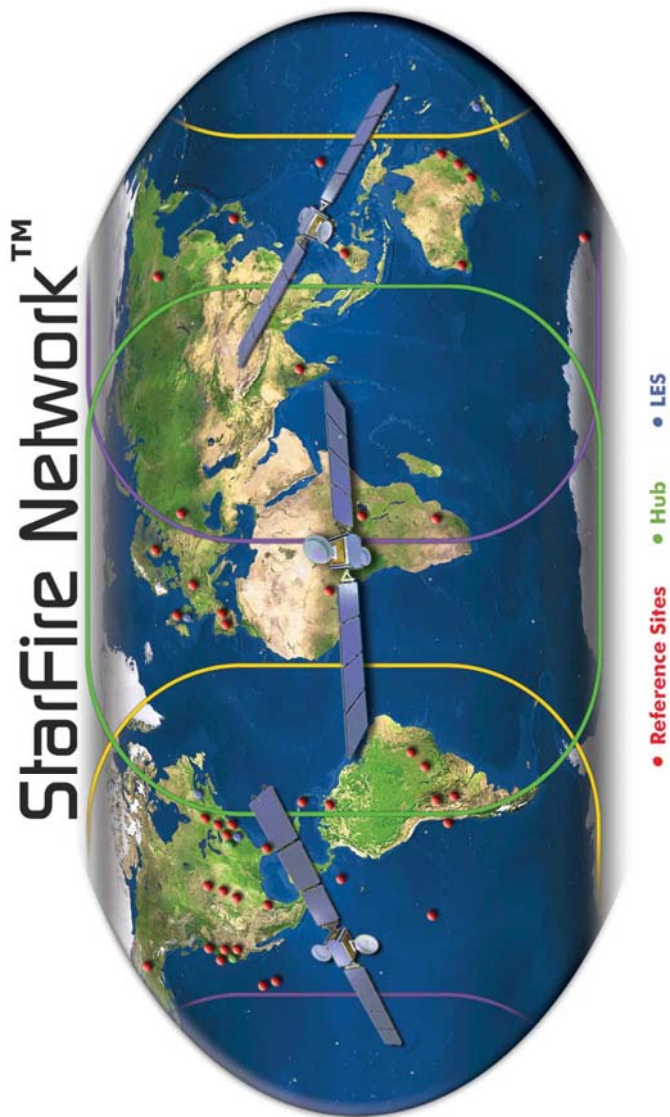


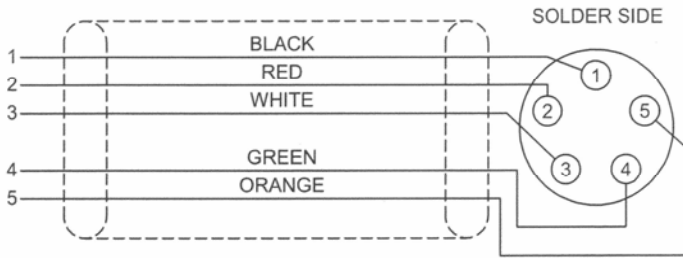
Figure C1: StarFire™ Network

## D ..... Event Input Configuration

Figure D1 details the wiring of the Event/Can cable assembly NavCom part number P/N 94-310062-3003.

Refer to Chapter 2, Event for detailed electrical specifications.

Table D1 details the wiring configuration required for Event-Hi, and Event-Lo pulse sensing.



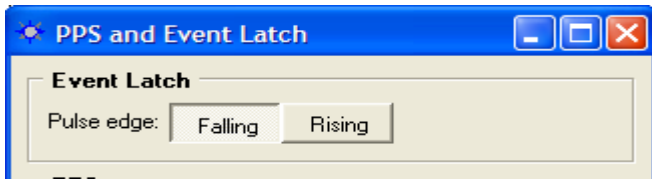
*Figure D1: Event Cable Wiring Diagram*

Pin #	Signal Name	Event Sync Wiring
1	Event Lo	Tie Event-Hi to Ground
2	Event Hi	Tie Event-Lo to Ground
3	Ground	N/A

*Table D1: Event Wiring Connections*

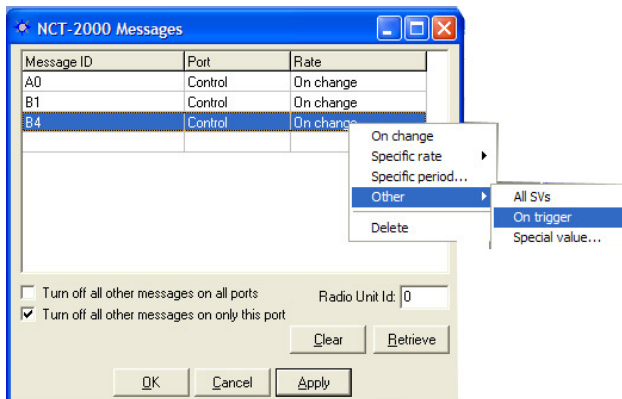
Once the cable is wired to correspond with the event pulse requirements, configure the receiver to output the message containing a time mark, referenced to the time kept within the receiver, indicating when the event is sensed (xB4).

The Event Input can be triggered on the Rising or Falling edge of the input pulse. Configuration is possible thru the StarUtil program. Figure D2 is a screen capture of the program’s PPS & Event Latch window.



*Figure D2: PPS & Event Latch Configuration*

Enable the Event Latch message (0xB4) in the NCT 2000 Message Output list. Set the Message Rate for 0xB4 to “On Trigger”. Right- Click on the Rate area adjacent to the B4 Message ID, and follow the menu as depicted in Figure D3. Once configured, the Event Latch Message (0xB4) is output upon recognition of an input trigger by the receiver.



*Figure D3: Event Latch Output Rate Configuration*

## Glossary

**.yym files** see meteorological files (where yy = two digit year data was collected).

**.yyn files** see navigation files (where yy = two digit year data was collected).

**.yyo files** see observation files (where yy = two digit year data was collected).

**almanac files** an almanac file contains orbit information, clock corrections, and atmospheric delay parameters for all satellites tracked. It is transmitted to a receiver from a satellite and is used by mission planning software.

**alt** see *altitude*.

**altitude** vertical distance above the *ellipsoid* or *geoid*. It is always stored as height above *ellipsoid* in the GPS receiver but can be displayed as height above *ellipsoid* (HAE) or height above *mean sea level* (MSL).

**Antenna Phase Center (APC)** The point in an antenna where the *GPS* signal from the satellites is received. The height above ground of the APC must be measured accurately to ensure accurate *GPS* readings. The APC height can be calculated by adding the height to an easily measured point, such as the base of the antenna mount, to the known distance between this point and the APC.

**APC** see *antenna phase center* or *phase center*.

**Autonomous positioning (GPS)** a mode of operation in which a GPS receiver computes *position* fixes in real time from satellite data alone, without reference to data supplied by a *reference station* or orbital clock corrections. Autonomous positioning is typically the least precise positioning procedure a

GPS receiver can perform, yielding *position* fixes that are precise to 100 meters with Selective Availability on, and 30 meters with S/A off.

**azimuth** the *azimuth* of a line is its direction as given by the angle between the *meridian* and the line measured in a clockwise direction from the north branch of the meridian.

**base station** see *reference station*.

**baud rate (*bits per second*)** the number of bits sent or received each second. For example, a *baud rate* of 9600 means there is a data flow of 9600 bits each second. One character roughly equals 10 bits.

**bits per second** see *baud rate*.

**bps** see *baud rate*.

**BSW (British Standard Whitworth)** a type of coarse screw thread. A 5/8" diameter *BSW* is the standard mount for survey instruments.

**C/A code** see *Coarse Acquisition code*.

**CAN BUS** a balanced (differential) 2-wire interface that uses an asynchronous transmission scheme. Often used for communications in vehicular applications.

**channel** a channel of a GPS receiver consists of the circuitry necessary to receive the signal for a single GPS satellite.

**civilian code** see *Coarse Acquisition code*.

**Coarse Acquisition code (C/A or Civilian code)** the pseudo-random code generated by *GPS* satellites. It is intended for civilian use and the accuracy of readings using this code can be degraded if *selective availability* (S/A) is introduced by the US Department of Defense.

**COM#** shortened form of the word Communications. Indicates a data communications port to/from the GPS sensor to a controller or data collection device.

**Compact Measurement Record (CMR)** a standard format for DGPS corrections used to transmit corrections from a *reference station* to *rover* sensors. See *Related Standards in Notices*.

**controller** a device consisting of hardware and software used to communicate and manipulate the I/O functions of the GPS sensor.

**convergence period** (StarFire™) is the time necessary for the received StarFire™ signal corrections to be applied and the position filtered to optimal performance. The convergence period is typically 30 to 45 minutes to achieve <decimeter accuracy. This period may be overcome using the Quick Start method.

**data files** files that contain Proprietary, GPS, NMEA, RTCM, or any type of data logged from a GPS receiver.

**datum** A reference datum is a known and constant surface which can be used to describe the location of unknown points. Geodetic datums define the size and shape of the earth and the origin and orientation of the coordinate systems used to map the earth.

**DB9P** a type of electrical connector containing 9 contacts. The P indicates a plug pin (male).

**DB9S** a type of electrical connector containing 9 contacts. The S indicates a slot pin (female).

**DCE** Data Communications Equipment. Defined pin assignments based on the IEEE RS-232 signaling standard. See the Figure G-1:

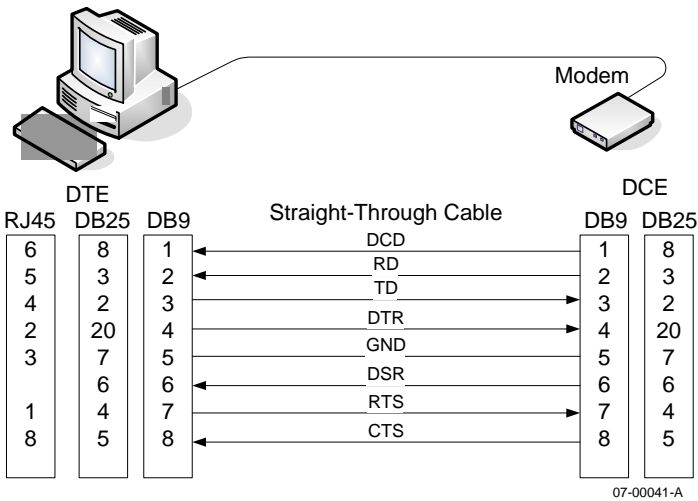


Figure G1: DTE to DCE RS-232 Pin Assignments

**DGPS** see *Differential GPS*.

**Differential GPS (DGPS)** a positioning procedure that uses two receivers, a rover at an unknown location and a reference station at a known, fixed location. The reference station computes corrections based on the actual and observed ranges to the satellites being tracked. The coordinates of the unknown location can be computed with sub-meter level precision by applying these corrections to the satellite data received by the rover.

**Dilution of Precision (DOP)** a class of measures of the magnitude of error in GPS *position* fixes due to the orientation of the GPS satellites with respect to the GPS receiver. There are several DOPs to measure different components of the error. Note: this is a unitless value. see also PDOP.

**DOP** see *Dilution of Precision*.

**DTE** Data Terminal Equipment. See *DCE*.

**dual-frequency** a type of GPS receiver that uses both L1 and L2 signals from GPS satellites. A dual-frequency receiver can compute more precise position fixes over longer distances and under more adverse conditions because it compensates for ionospheric delays. The SF-2050 is a dual frequency receiver.

**dynamic mode** when a GPS receiver operates in dynamic mode, it assumes that it is in motion and certain algorithms for GPS position fixing are enabled in order to calculate a tighter position fix.

**EGNOS (European Geostationary Navigation Overlay Service)** a European satellite system used to augment the two military satellite navigation systems now operating, the US GPS and Russian GLONASS systems.

**elevation** distance above or below Local Vertical Datum.

**elevation mask** the lowest elevation, in degrees, at which a receiver can track a satellite. Measured from the horizon to zenith, 0° to 90°.

**ellipsoid** a mathematical figure approximating the earth's surface, generated by rotating an ellipse on its minor axis. GPS positions are computed relative to the WGS-84 ellipsoid. An ellipsoid has a smooth surface, which does not match the earth's geoidal surface closely, so GPS altitude measurements can contain a large vertical error component. Conventionally surveyed positions usually reference a geoid, which has an undulating surface and approximates the earth's surface more closely to minimize altitude errors.

**epoch** literally a period of time. This period of time is defined by the length of the said period.

**geoid** the gravity-equipotential surface that best approximates mean sea level over the entire surface of the earth. The surface of a geoid is too irregular to use for GPS readings, which are measured relative to an ellipsoid. Conventionally surveyed positions reference a geoid. More accurate GPS readings can be obtained by calculating the distance between the geoid and ellipsoid at each position and subtracting this from the GPS altitude measurement.

**GIS (Geographical Information Systems)** a computer system capable of assembling, storing, manipulating, updating, analyzing and displaying geographically referenced information, i.e. data identified according to their locations. GIS technology can be used for scientific investigations, resource management, and development planning. GIS software is used to display, edit, query and analyze all the graphical objects and their associated information.

**Global Positioning System (GPS)** geometrically, there can only be one point in space, which is the correct distance from each of four known points. *GPS* measures the distance from a point to at least four satellites from a constellation of 24 NAVSTAR satellites orbiting the earth at a very high *altitude*. These distances are used to calculate the point's position.

**GMT** see *Greenwich Mean Time*.

**GPS** see *Global Positioning System*.

**GPS time** a measure of time. GPS time is based on UTC, but does not add periodic 'leap seconds' to correct for changes in the earth's period of rotation. As of September 2002 *GPS* time is 13 seconds ahead of UTC.

**Greenwich Mean Time (GMT)** the local time of the 0° meridian passing through Greenwich, England.

**HAE** see *altitude*, and *ellipsoid*.

**IODC** Issue of Data, Clock - The IODC indicates the issue number of the data set and thereby provides the user with a convenient means of detecting any change in the correction parameters. The transmitted IODC will be different from any value transmitted by the satellite during the preceding seven days.

**JPL** Jet Propulsion Laboratory.

**Kbps** kilobits per second.

**L-Band** the group of radio frequencies extending from approximately 400MHz to approximately 1600MHz. The GPS carrier frequencies L1 (1575.4MHz) and L2 (1227.6 MHz) are in the L-Band range.

**L1 carrier frequency** the primary L-Band carrier used by GPS satellites to transmit satellite data. The frequency is 1575.42MHz. It is modulated by C/A code, P-code, or Y-code, and a 50 bit/second navigation message. The bandwidth of this signal is 1.023MHz.

**L2 carrier frequency** the secondary L-Band carrier used by GPS satellites to transmit satellite data. The frequency is 1227.6MHz. It is modulated by P-code, or Y-code, and a 50 bit/second navigation message. The bandwidth of this signal is 10.23MHz.

**lat** see *latitude*.

**latitude (lat)** the north/south component of the coordinate of a point on the surface on the earth; expressed in angular measurement from the plane of the equator to a line from the center of the earth to the point of interest. Often abbreviated as Lat.

**LED** acronym for Light Emitting Diode.

**LEMO** a type of data or power connector.

**LES Land Earth Station** the point on the earth's surface where data is up linked to a satellite.

**logging interval** the frequency at which positions generated by the receiver are logged to data files.

**lon** see *longitude*.

**longitude (*long*)** the east/west component of the coordinate of a point on the surface of the earth; expressed as an angular measurement from the plane that passes through the earth's axis of rotation and the 0° meridian and the plane that passes through the axis of rotation and the point of interest. Often abbreviated as Long.

**Mean Sea Level (*MSL*)** a vertical surface that represents sea level.

**meridian** one of the lines joining the north and south poles at right angles to the equator, designated by degrees of longitude, from 0° at Greenwich to 180°.

**meteorological (.YYm) files** one of the three file types that make up the *RINEX* file format. Where YY indicates the last two digits of the year the data was collected. A meteorological file contains atmospheric information.

**MSL** see *Mean Sea Level*.

**multipath error** a positioning error resulting from interference between radio waves that has traveled between the transmitter and the receiver by two paths of different electrical lengths.

**navigation (.YYn) files** one of the three file types that make up the *RINEX* file format. Where YY indicates the last two digits of the year the data was collected. A navigation file contains satellite position and time information.

**observation (.YYo) files** one of the three file types that make up the *RINEX* file format. Where YY

indicates the last two digits of the year the data was collected. An observation file contains raw GPS position information.

**P/N** Part Number.

**P-code** the extremely long pseudo-random code generated by a *GPS* satellite. It is intended for use only by the U.S. military, so it can be encrypted to Y-code deny unauthorized users access.

**parity** a method of detecting communication errors by adding an extra parity bit to a group of bits. The parity bit can be a 0 or 1 value so that every byte will add up to an odd or even number (depending on whether odd or even parity is chosen).

**PDA** Personal Digital Assistant.

**PDOP** see *Position Dilution of Precision*.

**PDOP mask** the highest PDOP value at which a receiver computes positions.

**phase center** the point in an antenna where the GPS signal from the satellites is received. The height above ground of the phase center must be measured accurately to ensure accurate GPS readings. The phase center height can be calculated by adding the height to an easily measured point, such as the base of the antenna mount, to the known distance between this point and the phase center.

**Position** the latitude, longitude, and *altitude* of a point. An estimate of error is often associated with a position.

**Position Dilution of Precision (PDOP)** a measure of the magnitude of Dilution of Position (DOP) errors in the x, y, and z coordinates.

**Post-processing** a method of differential data correction, which compares data logged from a known reference point to data logged by a roving

---

receiver over the same period of time. Variations in the position reported by the reference station can be used to correct the positions logged by the roving receiver. Post-processing is performed after you have collected the data and returned to the office, rather than in real time as you log the data, so it can use complex, calculations to achieve greater accuracy.

**Precise code** see *P-code*.

**PRN (Uppercase)** typically indicates a *GPS* satellite number sequence from 1 – 32.

**prn (Lower Case)** see Pseudorandom Noise.

**Protected code** see *P-code*.

**Proprietary commands** those messages sent to and received from GPS equipment produced by NavCom Technology, Inc. own copyrighted binary language.

**pseudo-random noise (*prn*)** a sequence of data that appears to be randomly distributed but can be exactly reproduced. Each GPS satellite transmits a unique PRN in its signals. GPS receivers use PRNs to identify and lock onto satellites and to compute their pseudoranges.

**Pseudorange** the apparent distance from the reference station's antenna to a satellite, calculated by multiplying the time the signal takes to reach the antenna by the speed of light (radio waves travel at the speed of light). The actual distance, or range, is not exactly the same because various factors cause errors in the measurement.

**PVT** GPS information depicting Position, Velocity, Time in the NCT proprietary message format.

**Quick Start** (StarFire™) a startup mode that allows instant <decimeter accuracy with received StarFire™ signals, allowing the convergence period to be waived. The Quick Start (user input) position should

have an accuracy of better <decimeter to achieve maximum results. Any error in the user input position will bias the StarFire™ position error accordingly, until convergence can correct the bias. In this scenario, convergence may take longer than the typical startup convergence period.

**Radio Technical Commission for Maritime Services** see *RTCM*.

**range** the distance between a satellite and a GPS receiver's antenna. The *range* is approximately equal to the pseudorange. However, errors can be introduced by atmospheric conditions which slow down the radio waves, clock errors, irregularities in the satellite's orbit, and other factors. A GPS receiver's location can be determined if you know the ranges from the receiver to at least four GPS satellites. Geometrically, there can only be one point in space, which is the correct distance from each of four known points.

**RCP** a NavCom Technology, Inc. proprietary processing technique in which carrier phase measurements, free of Ionospheric and Troposphere effects are used for navigation.

**Real-Time Kinematic (RTK)** a GPS system that yields very accurate 3D *position* fixes immediately in real-time. The base station transmits its GPS position to roving receivers as the receiver generates them, and the roving receivers use the *base station* readings to differentially correct their own positions. Accuracies of a few centimeters in all three dimensions are possible. RTK requires dual frequency GPS receivers and high speed radio modems.

**reference station** a reference station collects GPS data for a fixed, known location. Some of the errors in the GPS positions for this location can be applied to

positions recorded at the same time by roving receivers which are relatively close to the reference station. A reference station is used to improve the quality and accuracy of GPS data collected by roving receivers.

**RHCP Right Hand Circular Polarization** used to discriminate satellite signals. GPS signals are RHCP.

**RINEX (Receiver Independent Exchange)** is a file set of standard definitions and formats designed to be receiver or software manufacturer independent and to promote the free exchange of GPS data. The *RINEX* file format consists of separate files, the three most commonly used are:

- the observation (.YYo) file,

- the navigation (.YYn) file,

- meteorological (.YYm) files; where YY indicates the last two digits of the year the data was collected.

**rover** any mobile GPS receiver and field computer collecting data in the field. A roving receiver's position can be differentially corrected relative to a stationary reference GPS receiver or by using *GPS* orbit and clock corrections from a SBAS such as StarFire™.

**roving receiver** see *rover*.

**RTCM** (Radio Technical Commission for Maritime Services) a standard format for Differential GPS corrections used to transmit corrections from a base station to rovers. RTCM allows both real-time kinematic (RTK) data collection and post-processed differential data collection. RTCM SC-104 (RTCM Special Committee 104) is the most commonly used version of RTCM message.

**RTK** see *Real-time kinematic*.

**RTG** Real Time GIPSY, a processing technique developed by NASA's *Jet Propulsion Laboratory* to provide a single set of real time global corrections for the GPS satellites.

**S/A** see *Selective Availability*.

**SBAS (Satellite Based Augmentation System)** this is a more general term, which encompasses WAAS, StarFire™ and EGNOS type corrections.

**Selective Availability (S/A)** is the deliberate degradation of the GPS signal by encrypting the P-code and dithering the satellite clock. When the US Department of Defense uses S/A, the signal contains errors, which can cause positions to be inaccurate by as much as 100 meters.

**Signal-to-Noise Ratio (SNR)** is a measure of a satellite's signal strength.

**single-frequency** is a type of receiver that only uses the L1 GPS signal. There is no compensation for ionospheric effects.

**SNR** see *signal-to-noise Ratio*.

**StarFire™** a set of real-time global orbit and clock corrections for GPS satellites. StarFire™ equipped receivers are capable of real-time decimeter positioning

(see Appendix C).

**Spread Spectrum Radio (SSR)** a radio that uses wide band, noise like (pseudo-noise) signals that are hard to detect, intercept, jam, or demodulate making any data transmitted secure. Because spread spectrum signals are so wide, they can be transmitted at much lower spectral power density (Watts per Hertz), than narrow band signals.

**SV (Space Vehicle)** a GPS satellite.

**Universal Time Coordinated (UTC)** a time standard maintained by the US Naval Observatory, based on local solar mean time at the Greenwich meridian. GPS time is based on UTC.

**UTC** see *Universal Time Coordinated*.

**WAAS (Wide Area Augmentation System)** a set of corrections for the GPS satellites, which are valid for the Americas region. They incorporate satellite orbit and clock corrections.

**WADGPS (Wide Area Differential GPS)** a set of corrections for the GPS satellites, which are valid for a wide geographic area.

**WGS-84 (World Geodetic System 1984)** the current standard datum for global positioning and surveying. The WGS-84 is based on the GRS-80 ellipsoid.

**Y-code** the name given to encrypted P-code when the U.S. Department of Defense uses selective availability.

This page is left blank intentionally